

FLUID PUMPS & EQUIPMENT INDIA PVT. LTD.

FIRE PROTECTION

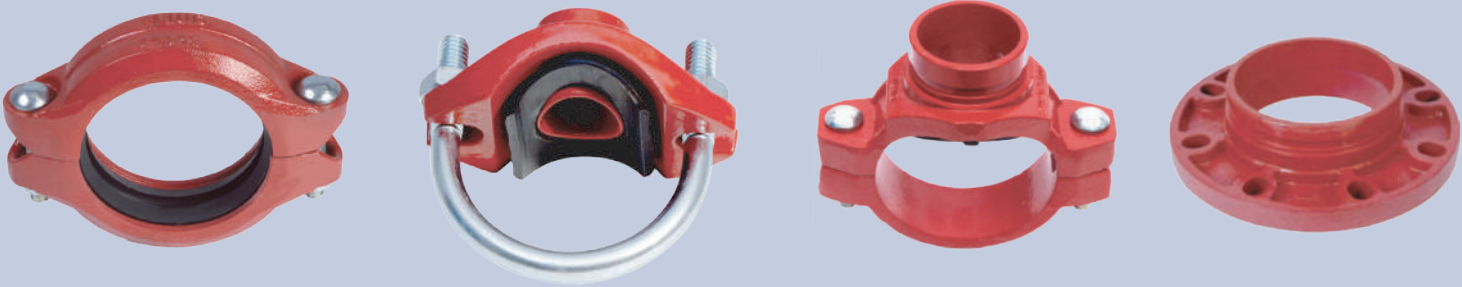

GROOVED FITTINGS

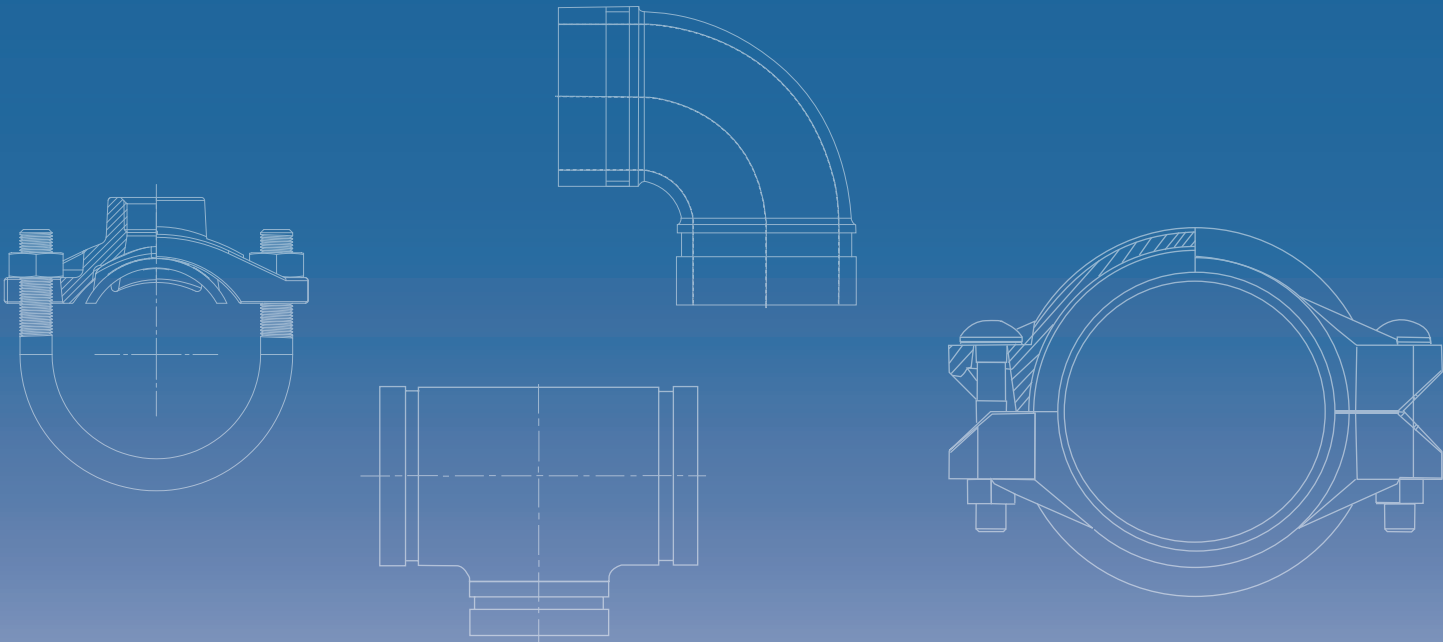

Style 311

Rigid Coupling



- FLUID® Style 311 Rigid Grooved Coupling features higher pressure ratings.
- FLUID® coupling provides better rigid connections for valves, fire mains, long straight runs etc.
- Coupling Housings are made of Ductile Iron conforming to ASTM A536 with rated working pressure up to 750 psi (52 bar).
- EPDM rubber Gaskets are suitable for installations with service temperature of -34°C to 105°C / -30°F to 221°F.
- FLUID® Couplings are supplied with Red painted RAL 3000 as standard. Other RAL colours or Galvanised finish is available upon request.
- Also suitable for Dry pipe application such as Deluge, CO2, Clean agent etc.

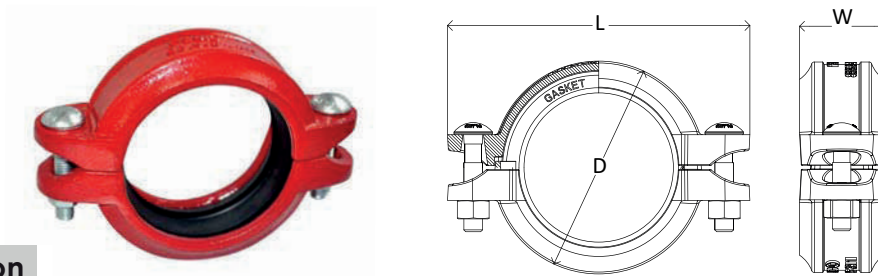

Specification

Nominal Size mm / in	Pipe O.D. mm / in	Maximum Working Pressure bar / psi	Dimensions			Weight kg / Lbs
			L mm / in	W mm / in	D mm / in	
25	33.4	52	98	46	57.2	0.57
1	1.31	750	3.86	1.81	2.25	1.2
32	42.2	52	108	46	66	0.58
1¼	1.66	750	4.25	1.81	2.60	1.3
40	48.3	52	114	46	72	0.68
1½	1.90	750	4.49	1.81	2.83	1.5
50	60.3	52	127	46	85	0.74
2	2.37	750	5.00	1.81	3.35	1.6
65	73.0	52	141	46	96	0.88
2½	2.87	750	5.55	1.81	3.78	1.9
65	76.1	52	144	46	99	0.89
3OD	3.50	750	5.67	1.81	3.90	1.9
80	88.9	52	162	46	114	1.08
3	3.50	750	6.38	1.81	4.49	2.4
100	114.3	35	184.5	50.5	145	1.49
4	4.50	500	7.26	1.99	5.71	3.3
150	168.3	28	255	50.5	202.5	2.50
6	6.63	400	10.04	1.99	7.97	5.51
150	165.1	28	252	50.5	199.5	2.47
6.5OD	6.50	400	9.92	1.99	7.85	5.45
200	219.1	20	326	58.5	258	4.32
8	8.63	300	12.83	2.30	10.16	9.52
250	273.0	20	405	65	320	8.56
10	10.75	300	15.94	2.56	12.60	18.9
300	323.5	20	465	65	376.5	10.59
12	12.75	300	18.31	2.56	14.82	23.3

Pressure Temperature Rating

Pipe Type	Grooved Type	Maximum Working Pressure	EPDM Gasket Service Temperature
EN10255 M/H	Roll	20 bar 300 psi	-34°C to 105°C -30°F to 221°F
Sch.40	Roll	52 bar 750 psi	-34°C to 105°C -30°F to 221°F

Housing

FLUID Coupling Housings are made of Ductile Iron confirming to ASTM A536 Gr. 65-45-12

Ductile iron is an ideal material for grooved mechanical components, as it provides similar or greater strength to that of wrought or cast steel materials

Chemical Properties

Percent (%)	Carbon C	Silicon Si	Manganese Mn	Phosphorous P	Sulphur S	Magnesium Mg	Chromium Cr
Min - Max	3% - 3.9%	2.5% - 3%	0.1% - 0.4%	0% - 0.07%	0% - 0.02%	0.03% - 0.05%	0% - 0.1%

Physical Properties

Minimum Tensile Strength	Minimum Yield Strength
448 MPa	310 MPa
65,000 psi	45,000 psi

Gaskets

FLUID Gaskets are made with EPDM rubber compound confirming to ASTM D2000 with properties equal or greater to required as per AWWA C606.

EPDM gaskets are suitable for water, waste water, sea water and deionized water.

EPDM gaskets are not suitable for petroleum based oils, fuels and hydrocarbon solvents.



Physical Properties

Material	Colour Code	Shore Hardness	Maximum Specific Gravity	Maximum Ash Content	Minimum Tensile Strength	Minimum Elongation %
EPDM	Green Mark	65 ± 5	1.1%	5%	10.34 MPa 1500 psi	300%

Bolts and Nuts

FLUID Bolts are oval neck track head made of carbon steel confirming to ASTM A183 Gr. 2 and heavy duty Nuts.

The bolts and Nuts are electro zinc plated with white passivation.



Chemical & Physical Properties of Bolts

Carbon C	Phosphorous P	Sulphur S	Chromium Cr	Tensile Strength	Yield Strength
0.3% Min.	0.05% Max	0.06% Max	0% - 0.1%	760 MPa 110,000 psi	550 MPa 80,000 psi

Note:

The information contained in this document is subject to change without notice due to continuous improvement process. FLUID shall not be liable for any errors contained herein.

Style 311

Rigid Coupling



- FLUID® Style 311 Rigid Grooved Coupling features moderate pressure ratings with lighter weights.
- FLUID® coupling provides better rigid connections for valves, fire mains, long straight runs etc.
- Coupling Housings are made of Ductile Iron conforming to ASTM A536 with rated working pressure up to 300 psi (20 bar).
- EPDM rubber Gaskets are suitable for installations with service temperature of -34°C to 105°C / -30°F to 221°F.
- FLUID® Couplings are supplied with Red painted RAL 3000 as standard. Other RAL colours or Galvanised finish is available upon request.

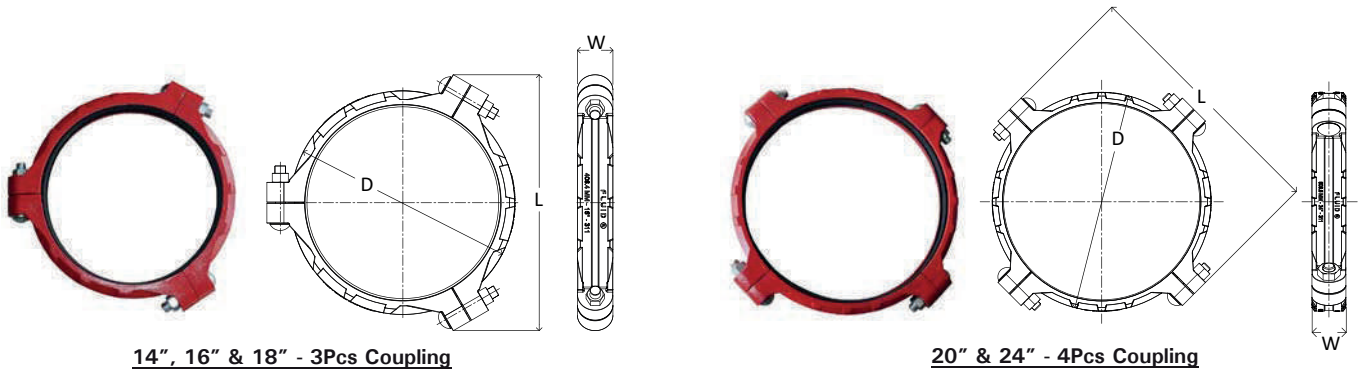

14", 16" & 18" - 3Pcs Coupling

20" & 24" - 4Pcs Coupling

Specification

Nominal Size mm / in	Pipe O.D. mm / in	Maximum Working Pressure ¹ bar / psi	Dimensions			Weight kg / Lbs	Approval
			L mm / in	W mm / in	D mm / in		
350	355.6	20	484	73	406	16.8	UL
14	14	300	19.05	2.87	15.98	37.03	UL
400	406.4	20	526	73	460	19.0	UL
16	16	300	20.70	2.87	18.11	41.88	UL
450	457.2	20	573	78	516.50	24.0	-
18	18	300	22.55	3.07	20.33	52.91	-
500	508	20	683.5	78	565	31.8	-
20	20	300	26.91	3.07	22.24	70.10	-
600	609.6	20	783	78	664	34.9	UL
24	24	300	30.82	3.07	26.14	76.94	UL

* At 2 feet between supports

Pressure Temperature Rating

Pipe Type	Grooved Type	Maximum Working Pressure	EPDM Gasket Service Temperature
EN10255 M/H	Roll	20 bar 300 psi	-34°C to 105°C -30°F to 221°F
Sch.40	Roll	20 bar 300 psi	-34°C to 105°C -30°F to 221°F

Housing

FLUID® Coupling Housings are made of Ductile Iron conforming to ASTM A536 Gr. 65-45-12
Ductile iron is an ideal material for grooved mechanical components, as it provides similar or greater strength to that of wrought or cast steel materials

Chemical Properties

Percent (%)	Carbon C	Silicon Si	Manganese Mn	Phosphorous P	Sulphur S	Magnesium Mg	Chromium Cr
Min - Max	3% - 3.9%	2.5% - 3%	0.1% - 0.4%	0% - 0.07%	0% - 0.02%	0.03% - 0.05%	0% - 0.1%

Physical Properties

Minimum Tensile Strength	Minimum Yield Strength
448 MPa	310 MPa
65,000 psi	45,000 psi

Gaskets

FLUID® Gaskets are made with EPDM rubber compound conforming to ASTM D2000 with properties equal or greater to required as per AWWA C606.

EPDM gaskets are suitable for water, waste water, sea water and deionized water.

EPDM gaskets are not suitable for petroleum based oils, fuels and hydrocarbon solvents.



Physical Properties

Material	Colour Code	Shore Hardness	Maximum Specific Gravity	Maximum Ash Content	Minimum Tensile Strength	Minimum Elongation %
EPDM	Green Mark	65 ± 5	1.1%	5%	10.34 MPa 1500 psi	300%

Bolts and Nuts

FLUID® Bolts are oval neck track head made of carbon steel conforming to ASTM A183 Gr. 2 and heavy duty Nuts.
The bolts and Nuts are electro zinc plated with white passivation.



Chemical & Physical Properties of Bolt

Carbon C	Phosphorous P	Sulphur S	Chromium Cr	Tensile Strength	Yield Strength
0.3% Min.	0.05% Max	0.06% Max	0% - 0.1%	760 MPa 110,000 psi	550 MPa 80,000 psi

Note:

The information contained in this document is subject to change without notice due to continues improvement process.
FLUID® shall not be liable for any errors contained herein.

Style 300

Grooved Mechanical Tee



- FLUID® Style 300 Grooved Mechanical Tee is designed for quick and economical connection of smaller branch pipes with Cross Mains or Riser Pipes.
- Mechanical Tee eliminates need for welding or cutting of the pipe mains for branch outlets. It allows quick installation with easy procedure of hole cut at desired outlet location and two track head bolts tightening.
- Groove dimensions confirm to AWWA C606.
- Mechanical Tee housings are made of Ductile Iron confirming to ASTM A536 with rated working pressure up to 500 psi (35 bar).
- EPDM rubber Gaskets are suitable for installations with service temperature of -34°C to 105°C / -30°F to 221°F.
- FLUID® Mechanical Tees are supplied with Red painted RAL 3000 as standard. Other RAL colours or Galvanized finish is available upon request.

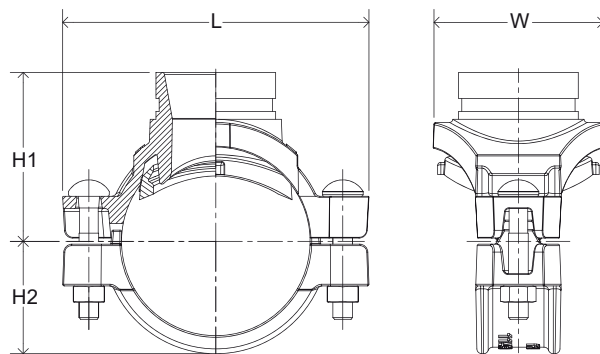

Specification

Nominal Size Run x Branch mm / in	Pipe O.D. mm / in	Maximum Working Pressure bar / psi			Dimensions				Weight kg / Lbs	Approval
		Sch. 40	Sch. 10	EN 10255	L mm / in	H1 mm / in	H2 mm / in	W mm / in		
80 x 40	88.9 X 48.3	35	-	-	160	95	53	99.2	2.19	-
3 x 1½	3.5 X. 37	500	-	-	6.3	3.74	2.08	3.91	4.83	-
80 X 50	88.9 X 60.3	35	-	-	160	95	53	97	2.30	UL
3 X 2	3.50X 2.37	500	-	-	6.30	3.74	2.08	3.81	5.05	UL
100 X 50	114.3 X 60.3	28	20	20	186.8	103	68.5	102.9	2.35	UL
4 X 2	4.500 X 2.375	400	300	300	7.35	4.06	2.70	4.05	5.18	UL
100 X 65	114.3 X 73	28	20	NA	186.8	103	68.5	102.9	2.52	UL
4 X 2½	4.500 X 2.875	400	300	NA	7.35	4.06	2.70	4.05	5.55	UL
100 X 80	114.3 X 88.9	35	-	-	186.8	103	68.5	121	2.89	UL
4 X 3	4.5 X 3.5	500	-	-	7.35	4.06	2.70	4.76	6.37	UL
150 X 50	168.3 X 60.3	28	20	NA	243.9	132.10	94.6	120	3.89	UL
6 X 2	6.625 X 2.375	400	300	NA	9.60	5.20	3.72	4.72	8.57	UL
150 X 65	168.3 X 73	28	20	NA	243.9	132.10	94.6	120	4.26	UL
6 X 2½	6.625 X 2.875	400	300	NA	9.60	5.20	3.72	4.72	9.39	UL
150 x 80	168.3 x 88.9	20	-	-	244	132.1	94.6	125	4.36	-
6 x 3	6.62 x 3.5	300	-	-	9.60	5.2	3.72	4.92	9.61	-
150 X 100	168.3 X 114.3	20	-	-	243.9	132.10	94.6	163	5.25	UL
6 X 4	6.625 X 4.5	300	-	-	9.60	5.20	3.72	6.42	11.57	UL
200X 50	219.1 X 60.3	20	-	-	320	164	123.3	128	6.10	UL
8 X 2	8.625 X 2.375	300	-	-	12.59	6.45	4.85	5.04	13.44	UL
200 X 65	219.1 X 73	20	-	-	320	164	123.3	128	6.25	UL
8 X 2½	8.625 X 2.875	300	-	-	12.59	6.45	4.85	5.04	13.77	UL

Housing

FLUID[®] Mechanical Tee Housings are made of Ductile Iron conforming to ASTM A536 Gr. 65-45-12. Ductile iron is an ideal material for grooved mechanical components, as it provides similar or greater strength to that of wrought or cast steel materials.

Chemical Properties

Percent (%)	Carbon C	Silicon Si	Manganese Mn	Phosphorous P	Sulphur S	Magnesium Mg	Chromium Cr
Min - Max	3% - 3.9%	2.5% - 3.2%	0.1% - 0.4%	0% - 0.07%	0% - 0.03%	0.03% - 0.06%	0% - 0.1%

Physical Properties

Minimum Tensile Strength	Minimum Yield Strength
448 MPa	310 MPa
65,000 psi	45,000 psi

Gaskets

FLUID[®] Gaskets are made with EPDM rubber compound confirming to ASTM D2000 as per AWWA C606 with properties equal or greater to required as per AWWA C606.

EPDM gaskets are suitable for water, waste water, sea water and deionized water.

EPDM gaskets are not suitable for petroleum based oils, fuels and hydrocarbon solvents.



Physical Properties

Material	Colour Code	Shore Hardness	Maximum Specific Gravity	Maximum Ash Content	Minimum Tensile Strength	Minimum Elongation %	Service Temp
EPDM	Green Mark	65 ± 5	1.1%	5%	10.34 MPa 1500 psi	300%	-34°C to 105°C -30°F to 221°F

Bolts and Nuts

FLUID[®] Bolts are oval neck track head made of carbon steel conforming to ASTM A183 Gr.2 / ISO 8.8 and Nuts are heavy duty. The bolts and Nuts are galvanized.



Chemical & Physical Properties of Bolts

Carbon C	Phosphorous P	Sulphur S	Chromium Cr	Tensile Strength	Yield Strength
0.3% Min.	0.05% Max	0.06% Max	0% - 0.1%	760 MPa 110,000 psi	550 MPa 80,000 psi

Hole Cutting Details

Mechanical Tee Branch Size mm / in	Hole Saw Dia. mm / in	W Dimension mm / in
50	64	114.3
2	2½	4½
65	70/76.2	121
2½	2¾/3	4¾
80	89	140
3	3½	5½

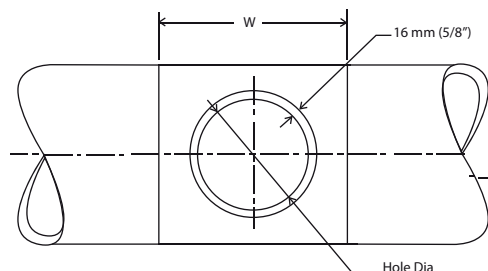

Note:

The information contained in this document is subject to change without notice due to continuous improvement process. FLUID shall not be liable for any errors contained herein.

Style 305

Threaded Mechanical Tee



- FLUID® Style 305 Threaded Mechanical Tee is designed for quick and economical connection of smaller branch pipes with Cross Mains or Riser Pipes.
- Mechanical Tee eliminates need for welding or cutting of the pipe mains for branch outlets. It allows quick installation with easy procedure of hole cut at desired outlet location and two track head bolts tightening.
- Outlet threads are female BSPT as standard. NPT threads can be provided as optional.
- Mechanical Tee housings are made of Ductile Iron conforming to ASTM A536 with rated working pressure up to 500 psi (35 bar).
- EPDM rubber Gaskets are suitable for installations with service temperature of -34°C to 105°C / -30°F to 221°F.
- FLUID® Mechanical Tees are supplied with Red painted RAL 3000 as standard. Other RAL colours or Galvanised finish is available upon request.

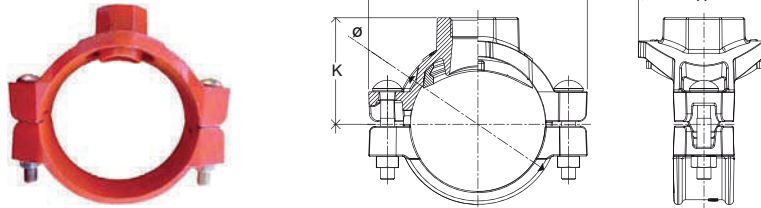

Specification

Nominal Size Run x Branch mm / in	Pipe O.D. mm / in	Maximum Working Pressure bar / psi	Hole Saw Dia. Mm/in	Dimensions				Weight kg / Lbs	Approval
				Ø mm / in	L mm / in	K mm / in	H mm / in		
40x25	48.3x33.7	35	34	71	105	53	60	0.76	UL
1½x1	1.90x1.32	500	1.34	2.79	4.13	2.08	2.36	1.68	UL
50x25	60.3x33.7	35	45	87	124	65	74	1.35	UL
2x1	2.375x1.32	500	1.75	3.44	4.88	2.56	2.91	2.97	UL
50x32	60.3x42.4	35	45	87	124	65	74	1.30	UL
2x1¼	2.37x1.67	500	1.75	3.44	4.88	2.56	2.91	2.86	UL
50x40	60.3x48.3	35	45	87	124	65	74	1.20	UL
2x1½	2.37x1.90	500	1.75	3.44	4.88	2.56	2.91	2.64	UL
65x25	73x33.7	35	45	96	143	75	84	1.28	UL
2½x1	2.87x1.32	500	1.75	3.78	5.63	2.95	3.30	2.82	UL
65x32	73x42.4	35	45	96	143	75	84	1.20	UL
2½x1¼	2.87x1.67	500	1.75	3.78	5.63	2.95	3.30	2.64	UL
65x40	73x48.3	35	45	98	143	75	84	1.30	UL
2½x1½	2.87x1.90	500	1.75	3.87	5.63	2.95	3.30	2.86	UL
65x50	73x60.3	35	51	98	143	75	90	1.60	-
2½x2	2.87x2.37	500	2.00	3.87	5.63	2.95	3.54	3.53	-
80x25	88.9x33.7	35	51	117	160	81	94	1.95	UL
3x1	3.50x1.32	500	2.00	4.60	6.30	3.19	3.68	4.29	UL
80x32	88.9x42.4	35	51	117	160	81	94	1.91	UL
3x1¼	3.50x1.67	500	2.00	4.60	6.30	3.19	3.68	4.21	UL
80x40	88.9x48.3	35	64	117	160	81	99.5	2.20	UL
3x1½	3.50x1.90	500	2.48	4.60	6.30	3.19	3.92	4.85	UL
80x50	88.9x60.3	35	64	117	160	81	99.5	2.00	UL
3x2	3.50x2.37	500	2.48	4.60	6.30	3.19	3.92	4.41	UL
100x25	114.3x33.7	35	51	144	186.8	91	93	2.30	UL
4x1	4.50x1.32	500	2.00	5.68	7.35	3.58	3.68	5.07	UL
100x32	114.3x42.4	35	51	144	186.8	91	93	2.17	UL
4x1¼	4.50x1.67	500	2.00	5.68	7.35	3.58	3.68	4.78	UL
100x40	114.3x48.3	35	64	144	186.8	91	112	2.51	UL
4x1½	4.50x1.90	500	2.48	5.68	7.35	3.58	4.42	5.53	UL
100x50	114.3x60.3	35	64	144	186.8	91	112	2.45	UL
4x2	4.50x2.37	500	2.52	5.68	7.35	3.58	4.42	5.40	UL
150x25	168.3x33.7	35	51	200.4	244	130	92.8	3.76	UL
6x1	6.62x1.32	500	2.00	7.89	9.60	5.12	3.65	8.29	UL
150x32	168.3x42.4	35	51	200.4	244	130	92.8	3.67	UL
6x1¼	6.62x1.67	500	2.00	7.89	9.60	5.12	3.65	8.10	UL
150x40	168.3x48.3	35	64	200.4	244	130	112	4.18	UL
6x1½	6.62x1.90	500	2.52	7.89	9.60	5.12	4.41	9.21	UL
150x50	168.3x60.3	35	64	200.4	244	130	112	4.13	UL
6x2	6.62x2.37	500	2.52	7.89	9.60	5.12	4.41	9.10	UL
150x65	168.3x73	20	70	200.4	244	130	114	4.27	-
6x2½	6.62x2.87	300	2.75	7.90	9.60	5.10	4.50	9.41	-

Nominal Size Run x Branch mm / in	Pipe O.D. mm / in	Maximum Working Pressure bar / psi	Hole Saw Dia. Mm/in	Dimensions			Weight kg / Lbs	Approval
				L mm / in	K mm / in	H mm / in		
200X25	219.1 X 33.7	20	51	320	157	95	5.65	UL
8X1	8.32 X 1.32	300	2.0	12.60	6.18	3.74	12.46	UL
200X32	219.1 X 42.4	20	51	320	157	95	5.57	UL
8X1¼	8.32 X 1.67	300	2.0	12.60	6.18	3.74	12.28	UL
200X40	219.1 X 48.3	20	64	320	157	127	6.14	UL
8X1½	8.32 X 1.90	300	2.5	12.60	6.18	5.00	13.54	UL
200X50	219.1 X 60.3	20	64	320	157	127	5.93	UL
8X2	8.32 X 2.37	300	2.5	12.60	6.18	5.00	13.07	UL
200X65	219.1 X 73.0	20	76.2	320	157	127	6.12	-
8X2½	8.32 X 2.87	300	3.0	12.60	6.18	5.00	13.49	-
250X40	273 X 48.3	20	64	375	185	132	8.15	-
10X1½	10.75 X 1.90	300	2.5	14.76	7.28	5.19	17.97	-
250X50	273 X 60.3	20	64	375	185	132	7.88	-
10X2	10.75 X 2.37	300	2.5	14.76	7.28	5.19	17.37	-

Housing

FLUID[®] Mechanical Tee Housings are made of Ductile Iron conforming to ASTM A536 Gr. 65-45-12. Ductile iron is an ideal material for grooved mechanical components, as it provides similar or greater strength to that of wrought or cast steel materials

Chemical & Physical Properties

Percent (%)	Carbon C	Silicon Si	Manganese Mn	Phosphorous P	Sulphur S	Magnesium Mg	Chromium Cr	Minimum Tensile Strength	Minimum Yield Strength
Min - Max	3% - 3.9%	2.5% - 3.2%	0.1% - 0.4%	0% - 0.07%	0% - 0.02%	0.03% - 0.06%	0% - 0.1%	448 MPa 65,000 psi	310 MPa 45,000 psi

Gaskets

FLUID[®] Gaskets are made with EPDM rubber compound conforming to ASTM D2000 with properties equal or greater to required as per AWWA C606.

EPDM gaskets are suitable for water, waste water, sea water and deionized water. EPDM gaskets are not suitable for petroleum based oils, fuels and hydrocarbon solvents.



Physical Properties

Material	Colour Code	Shore Hardness	Maximum Specific Gravity	Maximum Ash Content	Minimum Tensile Strength	Minimum Elongation %
EPDM	Green Mark	65 ± 5	1.1%	5%	10.34 MPa 1500 psi	300%

Bolts and Nuts

FLUID[®] Bolts are oval neck track head made of carbon steel conforming to ISO 8.8 and Nuts are heavy duty manufactured. The bolts and Nuts are galvanized.

Chemical & Physical Properties of Bolts

Carbon C	Phosphorous P	Sulphur S	Chromium Cr	Tensile Strength	Yield Strength
0.3% Min.	0.05% Max	0.06% Max	0% - 0.1%	760 MPa 110,000 psi	550 MPa 80,000 psi



Hole Cutting Details

Mechanical Tee Branch Size (mm / in)	Hole Saw Dia. (mm / in)	W Dimension (mm / in)
25	38	88.9
1	1½	3½
32	46	101.6
1¼	17/8	4
40	46	101.6
1½	17/8	4
50	64	114.3
2	2½	4½
65	70/16.2	121
2½	2¾/3	4¾

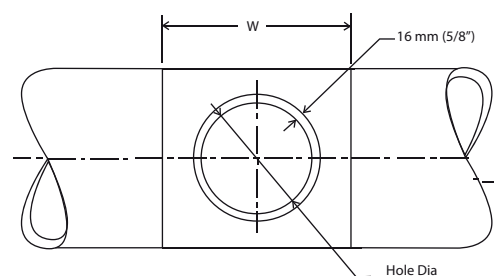

Note:

The information contained in this document is subject to change without notice due to continuous improvement process. FLUID shall not be liable for any errors contained herein.



FACTORY (IND)
7/222, Nagamanaickenpalayam
Pattanam, Coimbatore - 641016
Tamil Nadu, India

FOUNDRY (IND)
Gas Company Road
Idikarai, Coimbatore - 641022
Tamil Nadu, India

WAREHOUSE (UAE)
Plot: 599-2285
Jebel Ali Industrial Area-1
Dubai, UAE

Style 309

Sprinkler Outlet



- FLUID® Style 309 Sprinkler Outlet is designed for direct connection of sprinkler heads, pressure gauges, drop nipple or arm over pipe with length up to 610 mm / 2 Feet as per NFPA 13.
- Sprinkler Outlets eliminates need for welding or cutting of the pipes for branch outlets. It allows quick installation with easy procedure of hole cut and U bolt tightening on sprinkler mains or branch pipes at desired outlet location.
- Sprinkler Outlet housings are made of Ductile Iron conforming to ASTM A536 with rated working pressure up to 500 psi (35 bar).
- EPDM rubber Gaskets are suitable for installations with service temperature of -34°C to 105°C / -30°F to 221°F.
- FLUID® Sprinkler Outlets are supplied with Red painted RAL 3000 as standard. Other RAL colours or Galvanized finish is available upon request.

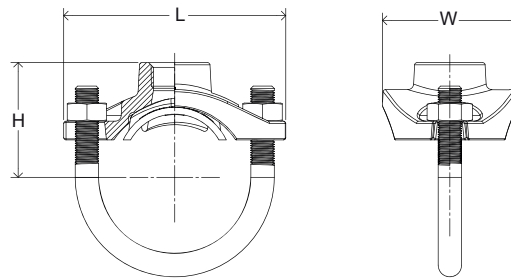

Specification

Nominal Size mm / in	Pipe O.D. mm / in	Maximum Working Pressure bar / psi			Dimensions			Weight (Kg/Lbs)	Approval
		Sch. 40	Sch. 10	EN 10255	L mm / in	W mm / in	H mm / in		
25 x 15	33.4x 21.3	35	-	-	74	44.7	37.3	0.25	-
1 x ½	1.31 x 0.84	500	-	-	2.91	1.76	1.47	0.55	-
32 x 15	42.2 x 21.3	35	-	-	82	55.5	39.7	0.31	-
1¼ x ½	1.66x 0.84	500	-	-	3.23	2.18	1.56	0.68	-
32 x 25	42.2 x 33.4	35	-	-	82	55.5	48.7	0.36	-
1¼ x 1	1.66 x 1.31	500	-	-	3.23	2.18	1.92	0.79	-
40 x 15	48.3 x 21.3	35	-	-	91	58	44	0.41	UL
1½ x ½	1.9 x 0.84	500	-	-	3.58	2.28	1.73	0.93	UL
40 x 25	48.3 x 33.4	35	-	-	91	58	51	0.47	UL
1½ x 1	1.9 x 1.31	500	-	-	3.58	2.28	2	1.04	UL
50 x 15	60.3 x 21.3	35	20	20	95	58	50.5	0.40	UL
2 x ½	2.37 x 0.84	500	300	300	3.74	2.28	1.98	0.88	UL
50 x 20	60.3 x 26.7	35	20	20	95	58	57.5	0.45	UL
2 x ¾	2.37 x 1.05	500	300	300	3.74	2.28	2.26	0.99	UL
50 x 25	60.3 x 33.4	35	20	20	95	58	63.5	0.49	UL
2 x 1	2.37 x 1.31	500	300	300	3.74	2.28	2.50	1.08	UL
65 x 15	73 x 21.3	35	20	-	110	59	63.5	0.60	UL
2½ x ½	2.87 x 0.84	500	300	-	4.33	2.32	2.50	1.32	UL
65 x 20	73 x 26.7	35	20	-	110	59	64.5	0.62	UL
2½ x ¾	2.87 x 1.05	500	300	-	4.33	2.32	2.53	1.36	UL
65 x 25	73 x 33.4	35	20	-	110	59	72.5	0.68	UL
2½ x 1	2.87 x 1.31	500	300	-	4.33	2.32	2.85	1.49	UL
80 x 15	88.9 X 21.3	35	-	-	123	60	69	0.76	UL
3 x ½	3.50 X 0.84	500	-	-	4.84	2.36	2.72	1.67	UL
80 x 25	88.9 x 33.4	35	-	-	123	60	79	0.80	UL
3 x 1	3.5 x 1.31	500	-	-	4.84	2.36	3.11	1.76	UL
100 x 15	114.3 x 21.3	35	-	-	160	99	90	1.35	UL
4 x ½	4.50 x 0.84	500	-	-	6.3	3.9	3.54	2.97	UL
100 X 25	114.3 X 33.4	35	-	-	160	98	98	1.40	UL
4 X 1	4.50 X 1.31	500	-	-	6.3	3.86	3.86	3.08	UL
150 x 15	168.3 x 21.3	35	-	-	225	99	120	2.2	UL
6 x ½	6.62 x 0.84	500	-	-	8.86	3.9	4.72	4.85	UL
150X25	168.3 X 33.4	35	-	-	225	100	120	2.2	UL
6X1	6.62 X 1.31	500	-	-	8.86	3.94	4.72	4.85	UL

Housing

FLUID Sprinkler Outlet Housings are made of Ductile Iron conforming to ASTM A536 Gr. 65-45-12.

Ductile iron is an ideal material for grooved mechanical components, as it provides similar materials or greater strength to that of wrought or cast steel materials.

Chemical Properties

Percent (%)	Carbon C	Silicon Si	Manganese Mn	Phosphorous P	Sulphur S	Magnesium Mg	Chromium Cr
Min - Max	3% - 3.9%	2.5% - 3.2%	0.1% - 0.4%	0% - 0.07%	0% - 0.03%	0.03% - 0.06%	0% - 0.1%

Physical Properties

Minimum Tensile Strength	Minimum Yield Strength
448 MPa	310 MPa
65,000 psi	45,000 psi

Gaskets

FLUID Gaskets are made with EPDM rubber compound conforming to ASTM D2000 with properties equal or greater to required as per AWWA C606.

EPDM gaskets are suitable for water, waste water, sea water and deionized water.

EPDM gaskets are not suitable for petroleum based oils, fuels and hydrocarbon solvents.



Physical Properties

Material	Colour Code	Shore Hardness	Maximum Specific Gravity	Maximum Ash Content	Minimum Tensile Strength	Minimum Elongation %
EPDM	Green Mark	65 ± 5	1.10%	5%	10.34 MPa 1500 psi	300%

Bolts and Nuts

FLUID U Bolts are made of carbon steel conforming to ASTM A449 Type 1 and heavy duty Nuts. The bolts and Nuts are galvanised.



Chemical & Physical Properties of Bolts

Carbon C	Phosphorous P	Sulphur S	Chromium Cr	Tensile Strength	Yield Strength
0.3% Min.	0.05% Max	0.06% Max	0% - 0.1%	827 MPa 120,000 psi	634 MPa 92,000 psi

Hole Cutting Details

Sprinkler Outlet Branch Size mm / in	Hole Dimensions (mm / in)		W Dimension mm / in
	Pipe Size (1" & 1¼)	Pipe Size (1½" to 6")	
15, 20, 25	24	30	88.9
½, ¾, 1	0.94	1.18	3½

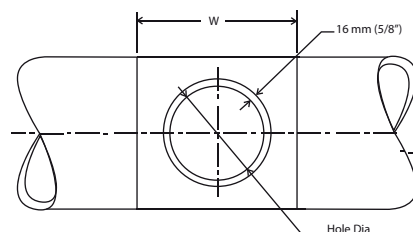

Note:

The information contained in this document is subject to change without notice due to continuous improvement process. FLUID shall not be liable for any errors contained herein.



FACTORY (IND)
7/222, Nagamaaickenpalayam
Pattanam, Coimbatore - 641016
Tamil Nadu, India

FOUNDRY (IND)
Gas Company Road
Idikarai, Coimbatore - 641022
Tamil Nadu, India

WAREHOUSE (UAE)
Plot: 599-2285
Jebel Ali Industrial Area-1
Dubai, UAE

Style 313

Flexible Coupling



- FLUID® Style 313 Flexible Grooved Coupling features moderate pressure ratings with lighter weights.
- Flexible couplings are designed to accommodate more angular movement and axial displacement for better flexibility of installations.
- Flexible coupling provides better protection in seismic events and helps to reduce noise and vibration.
- Flexible coupling housings are made of Ductile Iron conforming to ASTM A536 with rated working pressure up to 500 psi (35 bar).
- EPDM rubber Gaskets are suitable for installations with service temperature of -40°C to 105°C / -40°F to 221°F.
- FLUID® Style 313 is suitable for use in dry pipe system for temperature to -40°F as per UL Listing.
- FLUID® Couplings are supplied with Red painted RAL 3000 as standard. Other RAL colours or Galvanised finish is available upon request.

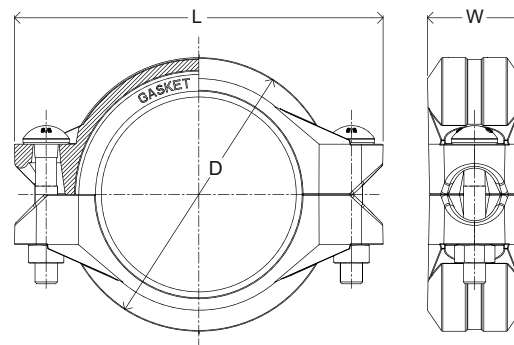

Specification

Nominal Size mm / in	Pipe O.D. mm / in	Maximum Working Pressure ¹ bar / psi			Load for Bending Moment ² kN / Lbs	Axial Displacement mm / in	Minimum Angular Movement Per Coupling	Dimensions			Weight kg / Lbs	Approval
		Sch. 40	Sch. 10	EN 10255				L mm / in	W mm / in	D mm / in		
40	48.3	35	-	-	7.20	4.5	1°	109	46	73.5	0.73	UL
1½	1.90	500	-	-	1620	0.177	1°	4.29	1.81	2.89	1.60	UL
50	60.3	35	20	20	10.23	6.5	1°	125	46	87	0.89	UL
2	2.37	500	300	300	2300	0.256	1°	4.92	1.81	3.43	1.96	UL
65	73.0	35	20	-	15.74	3.0	1°	142	46	100	1.10	UL
2½	2.87	500	300	-	3540	0.118	1°	5.59	1.81	3.42	2.42	UL
80	88.9	35	20	20	21.57	4.0	1°	162	46	118	1.36	UL
3	3.5	500	300	300	4850	0.157	1°	6.37	1.81	4.46	2.99	UL
100	114.3	35	20	20	32.65	9.0	1°	198	50	147	2.05	UL
4	4.5	500	300	300	7340	0.354	1°	7.79	1.96	5.78	4.51	UL
150	168.3	20	20	20	63.07	4.0	1°	249	50	198	3.55	UL
6	6.62	300	300	300	14180	0.157	1°	9.80	1.96	7.81	7.82	UL
200	219.1	20	20	20	100.61	11.0	1°	320	59	253	6.45	UL
8	8.62	300	300	300	22620	0.433	1°	12.59	2.32	9.96	14.20	UL
250	273	20	20	20	149.49	4.0	0.5°	401	63	317	11.50	UL
10	10.75	300	300	300	33610	0.157	0.5°	15.78	2.48	12.48	25.35	UL
300	323.5	20	20	20	204.34	3.0	0.5°	455	64	375	13.15	UL
12	12.75	300	300	300	45940	0.120	0.5°	17.91	2.52	14.76	28.99	UL

¹ For Sch.40 Roll Grooved Pipes

² At 2 feet between Supports

Pressure Temperature Rating

Pipe Type	Grooved Type	Maximum Working Pressure	EPDM Gasket Service Temperature
EN10255 M/H	Roll	20 bar 300 psi	-34°C to 105°C -30°F to 221°F
Sch.40	Roll	35 bar 500 psi	-34°C to 105°C -30°F to 221°F

Housing

FLUID[®] Coupling Housings are made of Ductile Iron confirming to ASTM A536 Gr. 65-45-12. Ductile iron is an ideal material for grooved mechanical components, as it provides similar or greater strength to that of wrought or cast steel materials.

Chemical Properties

Percent (%)	Carbon C	Silicon Si	Manganese Mn	Phosphorous P	Sulphur S	Magnesium Mg	Chromium Cr
Min - Max	3% - 3.9%	2.5% - 3.2%	0.1% - 0.4%	0% - 0.07%	0% - 0.03%	0.03% - 0.06%	0% - 0.1%

Physical Properties

Minimum Tensile Strength	Minimum Yield Strength
448 MPa	310 MPa
65,000 psi	45,000 psi

Gaskets

FLUID[®] Gaskets are made with EPDM rubber compound confirming to ASTM D2000 with properties equal or greater to required as per AWWA C606.

EPDM gaskets are suitable for water, waste water, sea water and deionized water. EPDM gaskets are not suitable for petroleum based oils, fuels and hydrocarbon solvents.



Physical Properties

Material	Colour Code	Shore Hardness	Maximum Specific Gravity	Maximum Ash Content	Minimum Tensile Strength	Minimum Elongation %
EPDM	Green Mark	65 ± 5	1.1%	5%	10.34 MPa 1500 psi	300%

Bolts and Nuts

FLUID[®] Bolts are oval neck track head made of carbon steel confirming to ASTM A183 Gr.2 / ISO 8.8 and Nuts are heavy duty. The bolts and Nuts are galvanized.



Chemical & Physical Properties of Bolts

Carbon C	Phosphorous P	Sulphur S	Chromium Cr	Tensile Strength	Yield Strength
0.3% Min.	0.05% Max	0.06% Max	0% - 0.1%	760 MPa 110,000 psi	550 MPa 80,000 psi

Note:

The information contained in this document is subject to change without notice due to continuous improvement process. FLUID[®] shall not be liable for any errors contained herein.

Style 313A

Stainless Steel Flexible Coupling



- FLUID® Style 313A Flexible Grooved Coupling features moderate pressure ratings with lighter weights.
- Flexible couplings are designed to accommodate more angular movement and axial displacement for better flexibility of installations.
- Flexible coupling provides better protection in seismic events and helps to reduce noise and vibration.
- Coupling Housings are made of Stainless Steel conforming to ASTM A351 CF8M with rated working pressure up to 500 psi (35 bar).
- EPDM rubber Gaskets are suitable for installations with service temperature of -34°C to 105°C / -30°F to 221°F.
- Suitable to be used in corrosive environments.

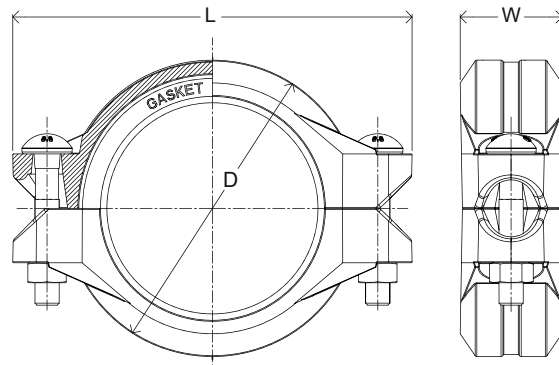

Specification

Nominal Size mm / in	Pipe O.D. mm / in	Maximum Working Pressure ¹ bar / psi	Load for Bending Moment ² kN / Lbs	Axial Displacement mm / in	Minimum Angular Movement Per Coupling	Dimensions			Weight kg / Lbs	Approval
						L mm / in	W mm / in	D mm / in		
50	60.3	35	11	3.6	1°	125	46	84	0.835	UL
2	2.37	500	2473	0.14	1°	4.92	1.81	3.31	1.84	UL
65	73	35	16	4	1°	141	46	95	0.925	UL
2½	2.87	500	3597	0.16	1°	5.55	1.81	3.74	2.04	UL
80	88.9	35	22.00	28	1°	161	46	112.5	1.26	UL
3	3.5	500	4946	0.11	1°	6.34	1.81	4.43	2.78	UL

¹ For Sch.40 Roll Grooved Pipes

² At 2 feet between Supports

Housing

FLUID® Coupling Housings are made of StainlessSteel conforming to ASTM A351 CF8M.

Stainless Steel is an ideal material for grooved mechanical components, as it provides similar or greater strength to that of wrought or cast steel materials.

Chemical Properties

Percent (%)	Carbon C	Silicon Si	Manganese Mn	Phosphorous P	Sulphar S	Nickel Ni	Chromium Cr	Molybedenum Mo
Min - Max	0.08%	1.50%	1.50%	0.04%	0.04%	9.0% - 12.0%	18.0% - 21.0%	2.0% - 3.0%

Physical Properties

Minimum Tensile Strength	Minimum Yield Strength
485 MPa	205 MPa
70,000 psi	30,000 psi

Pressure Temperature Rating

Pipe Type	Grooved Type	Maximum Working Pressure	EPDM Gasket Service Temperature
EN10255 M/H	Roll	20 bar 300 psi	-34°C to 105°C -30°F to 221°F
Sch.40	Roll	35 bar 500 psi	-34°C to 105°C -30°F to 221°F

Gaskets

FLUID® Gaskets are made with EPDM rubber compound conforming to ASTM D2000 with properties equal or greater to required as per AWWA C606.

EPDM gaskets are suitable for water, waste water, sea water and deionized water.

EPDM gaskets are not suitable for petroleum based oils, fuels and hydrocarbon solvents.



Physical Properties

Material	Colour Code	Shore Hardness	Maximum Specific Gravity	Maximum Ash Content	Minimum Tensile Strength	Minimum Elongation %
EPDM	Green Mark	65 ± 5	1.1 %	5%	10.34 MPa 1500 psi	300%

Bolts and Nuts

FLUID® Bolts are square neck track head made of Stainless Steel conforming to ASTM A193 Gr. B8M and Nuts are ASTM A194 Gr. 8M.



Chemical & Physical Properties of Bolts

Carbon C	Phosphorous P	Sulphur S	Chromium Cr	Tensile Strength	Yield Strength
0.08% Max.	0.045% Max.	0.030% Max.	16.0% - 18.0%	760 MPa 110,000 psi	655 MPa 95,000 psi

Note:

The information contained in this document is subject to change without notice due to continuous improvement process. FLUID shall not be liable for any errors contained herein.

Style 316



Reducing Coupling

- FLUID® Style 316 Grooved Reducing Coupling features moderate pressure ratings with lighter weights.
- Reducing coupling allows for direct reduction on a piping run and eliminates the need for a concentric reducer and couplings.
- The rubber gasket helps prevent small pipe from telescoping into larger pipe during vertical assembly.
- Reducing Coupling helps to accommodate more angular movement and axial displacement for better flexibility of installations.
- Reducing Coupling provides protection from seismic events and helps to reduce noise and vibration.
- Reducing Coupling Housings are made of Ductile Iron conforming to ASTM A536 with rated working pressure up to 500 psi (35 bar).
- EPDM rubber Gaskets are suitable for installations with service temperature of -34°C to 105°C / -30°F to 221°F.
- FLUID® Reducing Coupling are supplied with Red painted RAL 3000 as standard. Other RAL colours or Galvanised finish is available upon request.

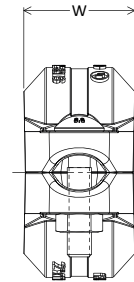
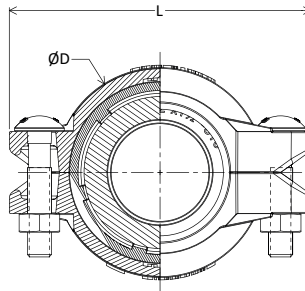

Specification

Nominal Size mm / in	Pipe O.D. mm / in	Maximum Working Pressure bar / psi	Load for Bending Moment kN / Lbs	Axial Displacement mm / in	Minimum Angular Movement Per Coupling	Dimensions			Weight kg / Lbs	Approval
						L mm / in	W mm / in	D mm / in		
50 x 40	60.3 x 48.3	35	10.23	6.5	1°	125.0	46	87.0	0.94	UL
2 x 1½	2.375 x 1.91	500	2300	0.256	1°	4.92	1.81	3.43	2.07	UL
65 x 50	73 x 60.3	35	15.74	3.0	1°	141.0	46	100.0	1.14	UL
2½ x 2	2.875 x 2.37	500	3540	0.118	1°	5.55	1.81	3.94	2.51	UL
80 x 50	88.9 x 60.3	35	21.57	4.0	1°	161.0	46	117.5	1.78	UL
3 x 2	3.5 x 2.37	500	4850	0.157	1°	6.34	1.81	4.63	3.92	UL
80 x 65	88.9 x 73	35	21.57	4.0	1°	161.0	46	117.5	1.67	UL
3 x 2½	3.5 x 2.875	500	4850	0.157	1°	6.34	1.81	4.63	3.68	UL
100 x 80	114.3 x 88.9	35	32.65	9.0	1°	198.0	50	147.0	2.45	UL
4 x 3	4.5 x 3.5	500	7340	0.354	1°	7.80	1.96	5.79	5.40	UL
150 x 100	168.3 x 114.3	20	63.07	4.0	1°	276	52	205	4.9	UL
6 x 4	6.62 x 4.5	300	14180	0.157	1°	10.87	2.05	8.07	10.8	UL

Housing

FLUID® Reducing Coupling Housings are made of Ductile Iron conforming to ASTM A536 Gr. 65-45-12

Ductile iron is an ideal material for grooved mechanical components, as it provides similar or greater strength to that of wrought or cast steel materials

Chemical Properties

Percent (%)	Carbon C	Silicon Si	Manganese Mn	Phosphorous P	Sulphur S	Magnesium Mg	Chromium Cr
Min - Max	3% - 3.9%	2.5% - 3.2%	0.1% - 0.4%	0% - 0.07%	0% - 0.02%	0.03% - 0.05%	0% - 0.1%

Physical Properties

Minimum Tensile Strength	Minimum Yield Strength
448 MPa	310 MPa
65,000 psi	45,000 psi

Gaskets

FLUID® Gaskets are made with EPDM rubber compound conforming to ASTM D2000 with properties equal or greater to required. EPDM gaskets are suitable for water, waste water, sea water and deionized water. EPDM gaskets are not suitable for petroleum based oils, fuels and hydrocarbon solvents.



Physical Properties

Material	Colour Code	Shore Hardness	Maximum Specific Gravity	Maximum Ash Content	Minimum Tensile Strength	Minimum Elongation %
EPDM	Green Mark	65 ± 5	1.1%	5%	10.34 MPa 1500 psi	300%

Bolts and Nuts

FLUID® Bolts are oval neck track head made of carbon steel conforming to ISO 8.8 and Nuts are heavy duty. The bolts and Nuts are galvanized.



Chemical & Physical Properties of Bolts

Carbon C	Phosphorous P	Sulphur S	Chromium Cr	Tensile Strength	Yield Strength
0.3% Min.	0.05% Max	0.06% Max	0% - 0.1%	760 MPa 110,000 psi	550 MPa 80,000 psi

Note:

The information contained in this document is subject to change without notice due to continues improvement process. FLUID® shall not be liable for any errors contained herein.

Style 350

Grooved Elbow - 90°



- FLUID® Style 350 Grooved Elbow features short center to end dimensions and it helps easier installation in less space.
- Grooved Elbow are primarily designed for fire protection applications, it can also be used for general services.
- Elbow Housings are made of Ductile Iron conforming to ASTM A536 with rated working pressure up to 500 psi (35 bar).
- FLUID Elbows are supplied with Red painted RAL 3000 as standard. Other RAL colours or Galvanised finish is available upon request.

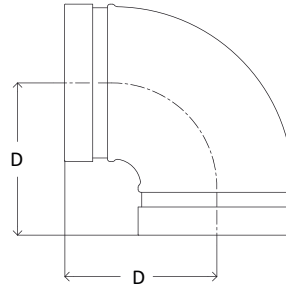

Specification

Nominal Size mm / in	Pipe O.D. mm / in	Maximum Working Pressure bar / psi	Equivalent Length of Pipe meters / feet	Dimensions D mm / in	Weight kg / Lbs	Approval
25	33.4	35	0.52	57	0.24	-
1	1.31	500	1.7	2.24	0.53	-
32	42.2	35	0.7	63.5	0.36	-
1¼	1.66	500	2.3	2.25	0.79	-
40	48.3	35	0.76	63.5	0.55	UL/FM
1½	1.90	500	2.5	2.5	1.21	UL/FM
50	60.3	35	0.94	69.8	0.65	UL/FM
2	2.37	500	3.1	2.75	1.43	UL/FM
65	73.0	35	1.09	76.2	0.86	UL/FM
2½	2.87	500	3.6	3.00	1.90	UL/FM
80	88.9	35	1.34	85.9	1.43	UL/FM
3	3.50	500	4.4	3.38	3.15	UL/FM
100	114.3	35	1.8	105.6	2.55	UL/FM
4	4.50	500	5.9	4.16	5.62	UL/FM
150	168.3	20	2.71	139.7	6.10	UL/FM
6	6.62	300	8.9	5.50	13.44	UL/FM
200	219.1	20	3.65	173	10.15	UL/FM
8	8.62	300	12.0	6.81	22.37	UL/FM
250	273.0	20	3.35	228.6	22.7	UL/FM
10	10.74	300	11.0	9.00	50.05	UL/FM
300	323.5	20	4.27	254	30.20	UL/FM
12	12.73	300	14.0	10.00	66.55	UL/FM

Housing

FLUID® Grooved Elbows are made of Ductile Iron conforming to ASTM A536 Gr. 65-45-12. Ductile iron is an ideal material for grooved mechanical components, as it provides similar or greater strength to that of wrought or cast steel materials.

Physical Properties

Minimum Tensile Strength	Minimum Yield Strength
448 MPa	310 MPa
65,000 psi	45,000 psi

Note:
The information contained in this document is subject to change without notice due to continuous improvement process. FLUID® shall not be liable for any errors contained herein.

Style 350A

Stainless Steel Elbow - 90°



- FLUID® Style 350A Grooved Elbow features short center to end dimensions and it helps easier installation in less space.
- Grooved Elbow are primarily designed for fire protection applications, it can also be used for general services.
- Elbow Housings are made of Stainless Steel confirming to ASTM A351 CF8M with rated working pressure up to 500 psi (35 bar).
- Suitable to be used in corrosive environments.
- Ideal for seawater or foam concentrates applications.

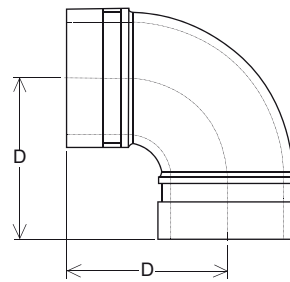

Specification

Nominal Size mm / in	Pipe O.D. mm / in	Maximum Working Pressure bar / psi	Equivalent Length of Pipe meters / feet	Dimensions D mm / in	Weight kg / Lbs	Approval
50	60.3	35	0.94	69.8	0.73	UL
2	2.37	500	3.08	2.75	1.62	UL
65	73.0	35	1.09	76.2	0.99	UL
2½	2.87	500	3.58	3.00	2.18	UL
80	88.9	35	1.34	85.9	1.39	UL
3	3.5	500	4.4	3.38	3.07	UL

Housing

FLUID® Grooved Elbows are made of Stainless Steel confirming to ASTM A351 CF8M. Stainless Steel is an ideal material for grooved mechanical components, as it provides similar or greater strength to that of wrought or cast steel materials.

Physical Properties

Minimum Tensile Strength	Minimum Yield Strength
485 MPa	205 MPa
70,000 psi	30,000 psi

Note:
The information contained in this document is subject to change without notice due to continuous improvement process. FLUID shall not be liable for any errors contained herein.

Style 351



Grooved Elbow - 45°

- FLUID® Style 351 Grooved Elbow features short center to end dimensions and it helps easier installation in less space.
- Grooved Elbow are primarily designed for fire protection applications, it can also be used for general services.
- Elbow Housings are made of Ductile Iron conforming to ASTM A536 with rated working pressure up to 500 psi (35 bar).
- FLUID® Elbows are supplied with Red painted RAL 3000 as standard. Other RAL colours or Galvanised finish is available upon request.

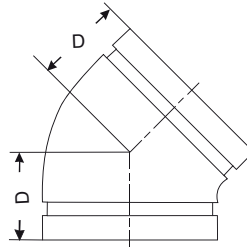

Specification

Nominal Size mm / in	Pipe O.D. mm / in	Maximum Working Pressure bar / psi	Equivalent Length of Pipe meters / feet	Dimensions D mm / in	Weight kg / Lbs	Approval
25	33.4	35	0.3	44	0.21	-
1	1.31	500	0.9	1.73	0.46	-
32	42.2	35	0.4	44	0.29	-
1¼	1.66	500	1.2	1.73	0.64	-
40	48.3	35	0.4	44	0.35	-
1½	1.90	500	1.3	1.73	0.77	-
50	60.3	35	0.5	42.9	0.55	UL/FM
2	2.37	500	1.7	1.69	1.20	UL/FM
65	73	35	0.6	45.7	0.77	UL/FM
2½	2.87	500	2.0	1.80	1.70	UL/FM
80	88.9	35	0.8	50.9	1.23	UL/FM
3	3.50	500	2.5	2.00	2.70	UL/FM
100	114.3	35	0.9	60.8	1.87	UL/FM
4	4.5	500	3.0	2.39	4.10	UL/FM
150	168.3	20	1.4	75.1	4.61	UL/FM
6	6.62	300	4.5	2.96	10.10	UL/FM
200	219.1	20	2.0	94.8	7.68	UL/FM
8	8.62	300	6.5	3.73	16.90	UL/FM
250	273	20	2.5	121.0	14.10	UL/FM
10	10.74	300	8.3	4.76	31.08	UL/FM
300	323.5	20	3.0	133.0	18.56	FM
12	12.74	300	9.8	5.24	40.92	FM

Housing

FLUID® Grooved Elbows are made of Ductile Iron conforming to ASTM A536 Gr. 65-45-12. Ductile iron is an ideal material for grooved mechanical components, as it provides similar or greater strength to that of wrought or cast steel materials.

Physical Properties

Minimum Tensile Strength	Minimum Yield Strength
448 MPa	310 MPa
65,000 psi	45,000 psi

Note:
The information contained in this document is subject to change without notice due to continuous improvement process. FLUID shall not be liable for any errors contained herein.

Style 358



Grooved Equal Tee

- FLUID® Style 358 Grooved Equal Tee features short center to end dimensions and it helps easier installation in less space.
- Grooved Tees are primarily designed for fire protection applications, it can also be used for general services.
- Grooved Tees Housings are made of Ductile Iron conforming to ASTM A536 with rated working pressure up to 500 psi (35 bar).
- FLUID® Grooved Tee are supplied with Red painted RAL 3000 as standard. Other RAL colours or Galvanised finish is available upon request.

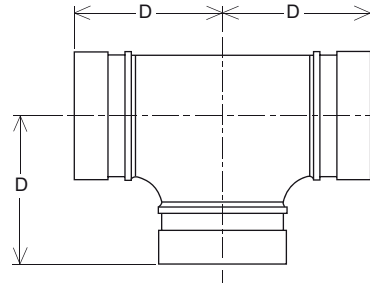

Specification

Nominal Size mm / in	Pipe O.D. mm / in	Maximum Working Pressure bar / psi	Equivalent Length of Pipe meters / feet	Dimensions D mm / in	Weight kg / Lbs	Approval
25	33.4	35	1.34	57	0.36	-
1	1.31	500	4.4	2.24	0.79	-
32	42.2	35	1.77	63.5	0.54	-
1¼	1.66	500	5.8	2.5	1.19	-
40	48.3	35	1.98	63.5	0.80	UL/FM
1½	1.9	500	6.5	2.50	1.76	UL/FM
50	60.3	35	2.6	69.8	0.91	UL/FM
2	2.37	500	8.5	2.75	2.00	UL/FM
65	73	35	3.1	76.2	1.28	UL/FM
2½	2.87	500	10.0	3.00	2.82	UL/FM
80	88.9	35	3.7	85.9	2.00	UL/FM
3	3.50	500	12.0	3.38	4.40	UL/FM
100	114.3	35	4.6	101.6	3.50	UL/FM
4	4.5	500	15.0	4.02	7.71	UL/FM
150	168.3	20	6.7	139.7	8.30	UL/FM
6	6.62	300	22.0	5.5	18.29	UL/FM
200	219.1	20	10.1	173	13.85	UL/FM
8	8.62	300	33.0	6.81	30.53	UL/FM
250	273	20	9.25	228	31.50	UL/FM
10	10.74	300	30.4	9.00	69.44	UL/FM
300	323.5	20	11.78	254	40.35	UL/FM
12	12.74	300	38.7	10.00	88.95	UL/FM

Housing

FLUID® Grooved Tees are made of Ductile Iron conforming to ASTM A536 Gr. 65-45-12. Ductile iron is an ideal material for grooved mechanical components, as it provides similar or greater strength to that of wrought or cast steel materials.

Physical Properties

Minimum Tensile Strength	Minimum Yield Strength
448 MPa	310 MPa
65,000 psi	45,000 psi

Note:
The information contained in this document is subject to change without notice due to continuous improvement process. FLUID shall not be liable for any errors contained herein.

Style 358A

Stainless Steel Equal Tee



- FLUID® Style 358A Grooved Equal Tee features short center to end dimensions and it helps easier installation in less space.
- Grooved Tees are primarily designed for fire protection applications, it can also be used for general services.
- Grooved Tees Housings are made of Stainless Steel conforming to ASTM A351 CF8M with rated working pressure up to 500 psi (35 bar).
- Suitable to be used in corrosive environments.
- Ideal for seawater or foam concentrates applications.

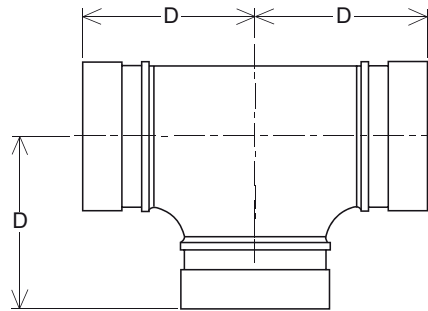

Specification

Nominal Size mm / in	Pipe O.D. mm / in	Maximum Working Pressure bar / psi	Equivalent Length of Pipe meters / feet	Dimensions D mm / in	Weight kg / Lbs	Approval
50	60.3	35	2	69.8	1.04	UL
2	2.37	500	6.56	2.75	2.31	UL
65	73.0	35	2.3	76.2	1.40	UL
2½	2.87	500	7.55	3.00	3.09	UL
80	88.9	35	2.85	85.9	1.94	UL
3	3.50	500	9.4	3.38	4.30	UL

Housing

FLUID® Grooved Tees are made of Stainless Steel conforming to ASTM A351 CF8M. Stainless Steel is an ideal material for grooved mechanical components, as it provides similar or greater strength to that of wrought or cast steel materials.

Physical Properties

Minimum Tensile Strength	Minimum Yield Strength
485 MPa	205 MPa
70,000 psi	30,000 psi

Note:
The information contained in this document is subject to change without notice due to continuous improvement process. FLUID shall not be liable for any errors contained herein.

Style 359



Grooved Reducing Tee

- FLUID® Style 359 Grooved Reducing Tee features short center to end dimensions and it helps easier installation in less space.
- Grooved Tees are primarily designed for fire protection applications, it can also be used for general services.
- Grooved Tees Housings are made of Ductile Iron conforming to ASTM A536 with rated working pressure up to 500 psi (35 bar).
- FLUID® Grooved Tee are supplied with Red painted RAL 3000 as standard. Other RAL colours or Galvanised finish is available upon request.

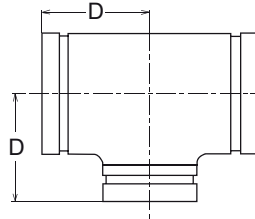

Specification

Nominal Size mm / in	Pipe O.D. mm / in	Maximum Working Pressure bar / psi	Equivalent Length of Pipe meters / feet	Dimensions D mm / in	Weight kg / Lbs	Approval
65 x 50	73 x 60.3	35	2.6	95.3	1.48	UL/FM
2½ x 2	2.87 x 2.37	500	8.5	3.75	3.26	UL/FM
80 x 50	88.9 x 60.3	35	2.6	69.8	2.35	UL/FM
3 x 2	3.5 x 2.37	500	8.5	2.75	5.18	UL/FM
80 x 65	88.9 x 76.1	35	3.1	76.2	2.48	UL/FM
3 x 2½	3.5 x 2.87	500	10.0	3.00	5.46	UL/FM
100 x 65	114.3 x 73	35	3.1	127	4.23	UL/FM
4 x 2½	4.5 x 2.87	500	10.0	5.00	9.33	UL/FM
100 x 80	114.3 x 88.9	35	3.7	85.9	4.45	UL/FM
4 x 3	4.5 x 3.50	500	12.0	3.38	9.81	UL/FM
150 x 65	168.3 x 73	20	3.1	165.1	9.14	UL/FM
6 x 2½	6.62 x 2.87	300	10.0	6.50	20.15	UL/FM
150 x 80	168.3 x 88.9	20	3.7	165.1	9.29	UL/FM
6 x 3	6.62 x 3.5	300	12.0	6.50	20.48	UL/FM
150 x 100	168.3 x 114.3	20	4.6	101.6	9.45	UL/FM
6 x 4	6.62 x 4.5	300	15.0	4.02	20.83	UL/FM
200 x 80	219.1 x 88.9	20	3.7	196.8	14.30	UL/FM
8 x 3	8.62 x 3.5	300	12	7.75	31.53	UL/FM
200 x 100	219.1 x 114.3	20	4.6	196.8	15.20	UL/FM
8 x 4	8.62 x 4.5	300	15.0	7.75	33.51	UL/FM
200 x 150	219.1 x 168.3	20	6.7	140	15.30	UL/FM
8 x 6	8.62 x 6.62	300	22.0	5.51	33.73	UL/FM
250 x 200	273 x 219.1	20	10.1	229	30.64	UL/FM
10 x 8	10.74 x 8.62	300	33	9	67.55	UL/FM
300 x 200	323.9 x 219.1	20	10.1	254	39.41	-
12 x 8	12.75 x 8.62	300	33	10	86.88	-
600 x 150	609.6 x 168.3	20	36	508	145	-
24 x 6	24 x 6.62	300	120	20	319.67	-

Housing

FLUID® Grooved Tees are made of Ductile Iron conforming to ASTM A536 Gr. 65-45-12.

Ductile iron is an ideal material for grooved mechanical components, as it provides similar or greater strength to that of wrought or cast steel materials.

Physical Properties

Minimum Tensile Strength	Minimum Yield Strength
448 MPa	310 MPa
65,000 psi	45,000 psi

Note:

The information contained in this document is subject to change without notice due to continuous improvement process. FLUID shall not be liable for any errors contained herein.

Style 361



Grooved Concentric Reducer

- FLUID Grooved Concentric Reducer style 361 designed for short center to end dimensions it helps in easier installation in less space.
- FLUID Grooved Concentric Reducers are primarily designed for fire protection applications, can also be used for general service
- Grooved Concentric Reducer housings are made of Ductile Iron conforming to ASTM A536 with rated working pressure up to 500 psi (35 bar).
- FLUID Concentric Reducer are supplied with Red painted RAL 3000 as standard. Other RAL colours or Galvanised finish is available upon request.

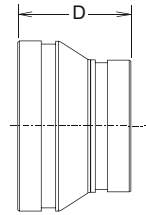

Specification

Nominal Size mm / in	Pipe O.D. mm / in	Maximum Working Pressure bar / psi	Dimensions D mm / in	Weight kg / Lbs	Approval
40 X 32	48.3X 42.2	35	64	0.28	-
1½ X 1¼	1.90 X 1.66	500	2.52	0.62	-
50 X 32	60.3 X 42.2	35	64	0.37	-
2 X 1¼	2.37 X 1.66	500	2.52	0.82	-
50 X 40	60.3X 48.3	35	64	0.42	UL/FM
2 X 1½	2.37 X 1.90	500	2.52	0.93	UL/FM
65 X 50	73 X 60.3	35	64	0.51	UL/FM
2½ X 2	2.87 X 2.37	500	2.52	1.12	UL/FM
80 X 50	88.9 X 60.3	35	64	0.59	UL/FM
3 X 2	3.50 X 2.37	500	2.52	1.30	UL/FM
76 X 65	88.9 X 73	35	64	0.63	UL/FM
3 X 2½	3.50 X 2.87	500	2.52	1.38	UL/FM
100 X 40	114.3 X 48.3	35	76.2	1.00	UL/FM
4 X 1½	4.5 X 1.9	500	3.00	2.20	UL/FM
100 X 50	114.3 X 60.3	35	76	1.04	UL/FM
4 X 2	4.50 X 2.37	500	3.00	2.29	UL/FM
100 X 65	114.3 X 73	35	76	1.03	UL/FM
4 X 2½	4.50 X 2.87	500	3.00	2.27	UL/FM
100 X 80	114.3 X 88.9	35	76	0.96	UL/FM
4 X 3	4.50 X 3.50	500	3.00	2.12	UL/FM
150 X 50	168.3 X 60.3	35	101.5	2.02	UL/FM
6 X 2	6.62 X 2.37	500	4.0	4.45	UL/FM
150 X 65	168.3 X 73	35	101.5	2.05	UL/FM
6 X 2½	6.62 X 2.87	500	4.0	4.52	UL/FM
150 X 80	168.3 X 88.9	20	101.5	2.09	UL/FM
6 X 3	6.62 X 3.5	300	4.0	4.61	UL/FM
150 X 100	168.3 X 114.3	20	102	2.33	UL/FM
6 X 4	6.62 X 4.50	300	4.02	5.15	UL/FM
200 X 100	219.1 X 114.3	20	127	5.11	UL/FM
8 X 4	8.62 X 4.50	300	5.00	11.26	UL/FM
200 X 150	219.1 X 168.3	20	127	5.88	UL/FM
8 X 6	8.60 X 6.62	300	5.00	12.97	UL/FM
250 X 100	273 X 114.3	20	152.4	7.35	UL/FM
10 X 4	10.75 X 4.5	300	6.0	16.20	UL/FM
250 X 200	273 X 219.1	20	152.40	7.60	UL/FM
10 X 8	10.75 X 8.60	300	6.00	16.75	UL/FM
300 X 200	323.9 X 219.1	20	178	11.07	UL
12 X 8	12.75 X 8.62	300	7.0	24.41	UL

Note:

The information contained in this document is subject to change without notice due to continues improvement process. FLUID shall not be liable for any errors contained herein.

Style 361A



Stainless Steel Concentric Reducer

- FLUID Grooved Concentric Reducer style 361 designed for short center to end dimensions it helps in easier installation in less space.
- FLUID Grooved Concentric Reducers are primarily designed for fire protection applications, can also be used for general services.
- Grooved Concentric Reducer housings are made of Stainless Steel conforming to ASTM A351 CF8M with rated working pressure up to 500 psi (35 bar).

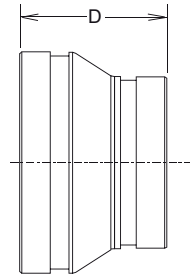

Specification

Nominal Size mm / in	Pipe O.D. mm / in	Maximum Working Pressure bar/psi	Dimensions D mm / in	Weight kg / Lbs	Approval
65 X 50	73 X 60.3	35	64	0.48	UL
2½ X 2	2.87 X 2.37	500	2.25	1.06	UL
80 X 65	88.9 X 73	35	64	0.70	UL
3 X 2½	3.50 X 2.87	500	2.25	1.54	UL

Housing

FLUID Grooved Concentric Reducers are made of Stainless Steel conforming to ASTM A351 CF8M. Stainless Steel is an ideal material for grooved mechanical components, as it provides similar or greater strength to that of wrought or cast steel materials

Physical Properties

Minimum Tensile Strength	Minimum Yield Strength
485 MPa	205 MPa
70,000 psi	30,000 psi

Note:
The information contained in this document is subject to change without notice due to continuous improvement process. FLUID shall not be liable for any errors contained herein.

Style 363



Concentric Reducer - Grooved/Threaded

- FLUID[®] Grooved/Threaded Concentric Reducer style 361 designed for short center to end dimensions it helps in easier installation in less space.
- FLUID[®] Grooved/Threaded Concentric Reducers are primarily designed for fire protection applications, can also be used for general services.
- Maximum working pressure 300 psi.
- Grooved/Threaded Concentric Reducer housings are made of Ductile Iron conforming to ASTM A536.
- Standard Finish: Red painted RAL 3000.
Optional Finish: Galvanised or any other RAL color available on request.

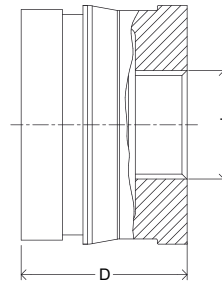

Specification

Nominal Size mm / in	Pipe O.D. mm / in	Thread Size T	Dimensions D mm / in	Weight kg / Lbs	Approval
65x25	73 x 33.4	1" BSPT/NPT	64	0.925	UL
2½x1	2.875x 1.31	1" BSPT/NPT	2.52	2.04	UL
65x32	73 x 42.2	1¼" BSPT/NPT	64	0.852	UL
2½x1¼	2.875x 1.66	1¼" BSPT/NPT	2.52	1.88	UL
65X40	73 x 48.3	1½" BSPT/NPT	64	0.794	UL
2½x1½	2.875x 1.9	1½" BSPT/NPT	2.52	1.75	UL
65x50	73 x 60.3	2" BSPT/NPT	64	0.66	UL
2½x2	2.875x 2.37	2" BSPT/NPT	2.52	1.46	UL
80X25	88.9 x 33.4	1" BSPT/NPT	64	1.297	UL
3x1	3.5x 1.31	1" BSPT/NPT	2.52	2.86	UL
80X32	88.9 x 42.2	1¼" BSPT/NPT	64	1.228	UL
3x1¼	3.5x 1.66	1¼" BSPT/NPT	2.52	2.71	UL
80X40	88.9 x 48.3	1½" BSPT/NPT	64	1.167	UL
3x1½	3.5x 1.90	1½" BSPT/NPT	2.52	2.57	UL
80X50	88.9 x 60.3	2" BSPT/NPT	64	1.036	UL
3x2	3.5x 2.37	2" BSPT/NPT	2.52	2.28	UL
80X65	88.9 x 73	2½" BSPT/NPT	64	0.820	UL
3x2½	3.5x 2.875	2½" BSPT/NPT	2.52	1.81	UL

Housing

FLUID[®] Concentric Reducers (G/T) are made of Ductile Iron conforming to ASTM A536 Gr. 65-45-12. Ductile iron is an ideal material for grooved mechanical components, as it provides similar or greater strength to that of wrought or cast steel materials

Physical Properties

Minimum Tensile Strength	Minimum Yield Strength
448 MPa	310 MPa
65,000 psi	45,000 psi

Note:
The information contained in this document is subject to change without notice due to continuous improvement process. FLUID shall not be liable for any errors contained herein.

Style 364

Grooved Elbow-90°-Long Radius



- FLUID® Style 364 Grooved Elbow features low friction loss compared to short radius.
- FLUID® Grooved Elbow are primarily designed for fire protection applications, it can also be used for general services.
- FLUID® Elbow Housings are made of Ductile Iron conforming to ASTM A536 with rated working pressure up to 500 psi (35 bar)
- FLUID® Elbows are supplied with Red painted RAL 3000 as standard. Other RAL colours or galvanised finish is available upon request.
- FLUID® Long Radius Elbow has low friction loss due to 1.5D Radius.

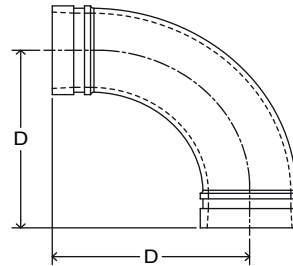

Specification

Nominal Size mm / in	Pipe O.D. mm / in	Maximum Working Pressure bar / psi	Dimensions	Weight (Kg/Lbs)	Approval
			D mm / in		
50	60.3	35	136	1.15	UL
2	2.37	500	5.35	2.54	UL
65	73	35	146	1.54	UL
2½	2.87	500	5.75	3.39	UL
80	88.9	35	181	2.79	UL
3	3.5	500	7.13	6.15	UL
100	114.3	35	191	4.54	UL
4	4.5	500	7.52	10.00	UL
150	168.3	20	273	11.42	UL
6	6.62	300	10.75	25.17	UL
200	219.1	20	381	23.50	UL
8	8.62	300	15.0	51.80	UL

Housing

FLUID® Grooved Elbows are made of Ductile Iron conforming to ASTM A536 Gr. 65-45-12. Ductile iron is an ideal material for grooved mechanical components, as it provides similar or greater strength to that of wrought or cast steel materials.

Chemical Properties

Percent (%)	Carbon C	Manganese Mn	Phosphorous P	Sulphur S	Magnesium Mg	Chromium Cr
Min - Max	3% - 3.9%	0.1% - 0.4%	0% - 0.07%	0% - 0.02%	0.03% - 0.05%	0% - 0.1%

Physical Properties

Minimum Tensile Strength	Minimum Yield Strength
448 MPa	310 MPa
65,000 psi	45,000 psi

Note:

The information contained in this document is subject to change without notice due to continuous improvement process. FLUID shall not be liable for any errors contained herein.

Style 369

Reducing Tee-Grooved/Threaded



- FLUID® Style 369 Grooved/Threaded Reducing Tee features short center to end dimensions and it helps easier installation in less space.
- Grooved/Threaded Tees are primarily designed for fire protection applications, it can also be used for general services.
- Grooved/Threaded Tees Housings are made of Ductile Iron conforming to ASTM A536 with rated working pressure up to 300 psi (20 bar).
- FLUID® Grooved/Threaded Tee are supplied with Red painted RAL 3000 as standard. Other RAL colours or Galvanised finish is available upon request.

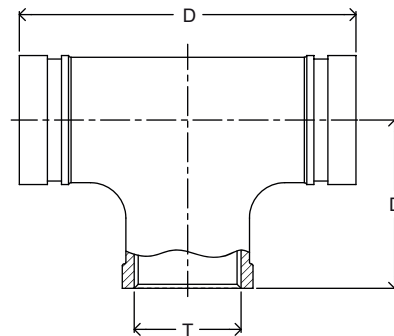

Specification

Nominal Size mm / in	Pipe O.D. mm / in	Thread Size T	Dimensions D mm / in	Weight kg / Lbs	Approval
65x50	73x60.3	2" BSPT/NPT	95.3	1.93	UL
2½x2	2.87x2.37	2" BSPT/NPT	3.8	4.25	UL

Housing

FLUID® Grooved Tees are made of Ductile Iron conforming to ASTM A536 Gr. 65-45-12.

Ductile iron is an ideal material for grooved mechanical components, as it provides similar or greater strength to that of wrought or cast steel materials.

Physical Properties

Minimum Tensile Strength	Minimum Yield Strength
448 MPa	310 MPa
65,000 psi	45,000 psi

Chemical Properties

Percent (%)	Carbon C	Manganese Mn	Phosphorous P	Sulphur S	Magnesium Mg	Chromium Cr
Min - Max	3% - 3.9%	0.1% - 0.4%	0% - 0.07%	0% - 0.02%	0.03% - 0.05%	0% - 0.1%

Note:

The information contained in this document is subject to change without notice due to continuous improvement process. FLUID® shall not be liable for any errors contained herein.

Style 371

Grooved End Cap



- FLUID Style 371 Grooved End Cap is designed to terminate grooved piping end for temporary or permanent basis.
- Grooved End Caps are supplied with blind connection as standard. 15 mm / 0.5 inch tapping with plug is available as optional to be used for pressure gauge or drain point connection. Groove Dimensions confirm to AWWA C606.
- End Cap Body is made of Ductile Iron conforming to ASTM A536 with rated working pressure up to 500 psi (35 bar).
- FLUID End Caps are supplied with Red painted RAL 3000 as standard. Other RAL colours or Galvanised finish is available upon request.



1 1/2"-12" End Cap

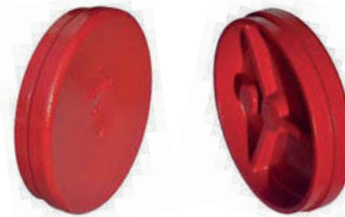
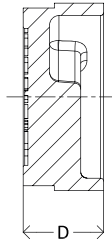

12" Above End Cap

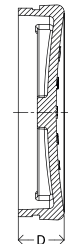

Specification

Nominal Size mm / in	Pipe O.D. mm / in	Maximum Working Pressure bar / psi	Groove Diameter mm / in	Dimensions D mm / in	Weight kg / Lbs	Approval
25	33.4	35	30.2	23.9	0.08	-
1	1.31	500	1.19	0.94	0.18	-
32	42.2	35	39	23.9	0.12	-
1 1/4	1.66	500	1.53	0.94	0.26	-
40	48.3	35	45	26	0.19	UL/FM
1 1/2	1.90	500	1.77	1.02	0.42	UL/FM
50	60.3	35	57.1	26	0.26	UL/FM
2	2.37	500	2.25	1.02	0.57	UL/FM
65	73	35	69.1	26	0.40	UL/FM
2 1/2	2.87	500	2.72	1.02	0.88	UL/FM
80	88.9	35	84.9	26	0.54	UL/FM
3	3.50	500	3.34	1.02	1.20	UL/FM
100	114.3	35	110.1	26	0.95	UL/FM
4	4.50	500	4.33	1.02	2.09	UL/FM
150	168.3	35	164.0	27	1.90	UL/FM
6	6.62	500	6.45	1.60	4.03	UL/FM
200	219.1	20	214.4	32	3.99	UL/FM
8	8.62	300	8.44	1.25	8.79	UL/FM
250	273.0	20	268.3	32	8.25	UL/FM
10	10.75	300	10.56	1.25	18.18	UL/FM
300	323.9	20	318.0	32	10.80	UL/FM
12	12.73	300	12.52	1.25	23.87	UL/FM
350	355.6	20	350.0	78	20.58	UL/FM
14	14.00	300	13.78	3.07	43.47	UL/FM
400	406.4	20	400.84	80	28.00	UL/FM
16	16.00	300	15.78	3.15	61.72	UL/FM

Housing

FLUID End Caps are made of Ductile Iron conforming to ASTM A536 Gr. 65-45-12.

Ductile iron is an ideal material for grooved mechanical components, as it provides similar or greater strength to that of wrought or cast steel materials

Physical Properties

Minimum Tensile Strength	Minimum Yield Strength
448 MPa	310 MPa
65,000 psi	45,000 psi

Note:

The information contained in this document is subject to change without notice due to continuous improvement process. FLUID shall not be liable for any errors contained herein.

Style 373

Grooved Flange



- FLUID® Style 373 Grooved Flange is designed to provide a rigid transition from a flanged component to a grooved piping system.
- Grooved Flanges are supplied as per ANSI Class 125 drilling pattern as standard. Groove Dimensions confirm to AWWA C606.
- Flange Body is made of Ductile Iron confirming to ASTM A536 with rated working pressure up to 500 psi (35 bar).
- Grooved Flanges are supplied with Flat Face as Standard. Raised Face Flange available as optional.
- FLUID® Flanges are supplied with Red painted RAL 3000 as standard. Other RAL colours or Galvanised finish is available upon request.

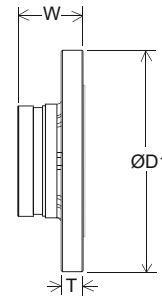
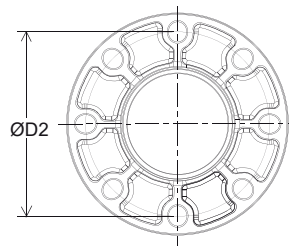

Specification

Nominal Size mm / in	Pipe O.D. mm / in	Maximum Working Pressure bar / psi	Dimensions				Weight kg / Lbs	Approval
			D1 mm / in	D2 mm / in	W mm / in	T mm / in		
65	73	24	178.92	139.70	65.00	22.35	2.99	UL/FM
2½	2.37	350	7.04	5.50	2.56	0.88	6.59	UL/FM
80	88.9	24	191.67	152.40	65.00	22.35	3.30	UL/FM
3	3.50	350	7.55	6.00	2.56	0.88	7.27	UL/FM
100	114.3	35	229.77	190.50	67	22.35	4.30	UL/FM
4	4.50	500	9.04	7.50	2.63	0.87	9.47	UL/FM
150	168.3	14	282	241.30	70	22.90	6.10	UL/FM
6	6.62	200	11.10	9.50	2.75	0.90	13.44	UL/FM
200	219.1	17	344.86	298.40	108	27	11.00	UL/FM
8	8.62	250	13.57	11.74	4.25	1.06	24.25	UL/FM
250	273	17	415	361.95	132	28.50	18.75	UL/FM
10	10.75	250	16.33	14.25	5.19	1.12	41.33	UL/FM
300	323.8	20	482.60	431.80	145	30.23	29.00	UL/FM
12	12.75	300	19	16.96	5.70	1.19	63.93	UL/FM
350	355.6	20	533	476.2	145	35	36.40	UL/FM
14	14	300	20.98	18.74	5.70	1.37	80.24	UL/FM
400	406.4	20	597	532.4	145	37	46.50	UL/FM
16	16	300	23.50	20.96	5.70	1.45	102.51	UL/FM
600	609.6	20	828	759.7	165	38	102	-
24	24	300	32.59	29.91	6.49	1.89	224.87	-

Housing

FLUID® Grooved flanges are made of Ductile Iron confirming to ASTM A536 Gr. 65-45-12.

Ductile iron is an ideal material for grooved mechanical components, as it provides similar or greater strength to that of wrought or cast steel materials

Physical Properties

Minimum Tensile Strength	Minimum Yield Strength
448 MPa	310 MPa
65,000 psi	45,000 psi

Note:

The information contained in this document is subject to change without notice due to continuous improvement process. FLUID shall not be liable for any errors contained herein.

Style 374

Threaded Flange

- FLUID® Style 374 Threaded Flange is designed to provide a rigid flanged component without welding.
- Threaded Flanges are supplied as per ANSI Class 125 drilling pattern as standard. Other drilling patterns PN16 or ANSI Class 250 are available as optional.
- Flange Body is made of Ductile Iron conforming to ASTM A536 with rated working pressure up to 500 psi (35 bar).
- Threaded Flanges are supplied with Flat Face as Standard. Raised Face Flange available as optional.
- FLUID® Flanges are supplied with Red painted RAL 3000 as standard. Other RAL colours available upon request.

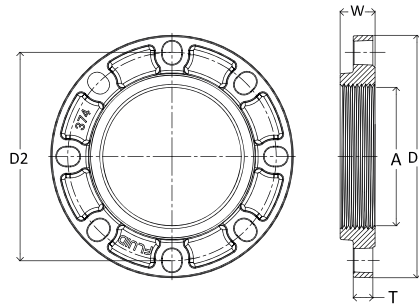

Specification

Nominal Size mm / in	Pipe O.D. mm / in	Maximum Working Pressure bar / psi	Dimensions					Weight kg / Lbs	Approval
			D1 mm / in	D2 mm / in	W mm / in	T mm / in	A		
100	114.3	35	229.5	190.5	34.5	22.3	4" NPT/BSP	4.29	-
4	4.50	500	9.04	7.50	1.36	0.88	4" NPT/BSP	9.45	-
150	168.3	35	282.0	241.3	40.5	22.9	6" NPT/BSP	6.78	-
6	6.62	500	11.10	9.50	1.59	0.90	6" NPT/BSP	14.95	-

Housing

FLUID Threaded Flange Housings are made of Ductile Iron conforming to ASTM A536 Gr. 65-45-12
Ductile iron is an ideal material for mechanical components, as it provides similar or greater strength to that of wrought or cast steel materials

Chemical Properties

Percent (%)	Carbon C	Silicon Si	Manganese Mn	Phosphorous P	Sulphur S	Magnesium Mg	Chromium Cr
Min - Max	3% - 3.9%	2.5% - 3.2%	0.1% - 0.4%	0% - 0.07%	0% - 0.03%	0.03% - 0.06%	0% - 0.1%

Physical Properties

Minimum Tensile Strength	Minimum Yield Strength
448 MPa	310 MPa
65,000 psi	45,000 psi

Note:

The information contained in this document is subject to change without notice due to continuous improvement process. FLUID shall not be liable for any errors contained herein.

Style 375

Split Flange



- FLUID® Style 375 Split Flange is designed to provide a rigid transition from a flanged component to a grooved piping system.
- Split Flanges are supplied as per ANSI Class 125 drilling pattern as standard. Other drilling patterns PN16 or ANSI Class 250 are available as optional. Groove Dimensions confirm to AWWA C606.
- Flange Body is made of Ductile Iron confirming to ASTM A536 with rated working pressure up to 500 psi (35 bar).
- Split Flanges are supplied with Flat Face as Standard. Raised Face Flange available as optional.
- FLUID® Flanges are supplied with Red painted RAL 3000 as standard. Other RAL colours or Galvanised finish is available upon request.

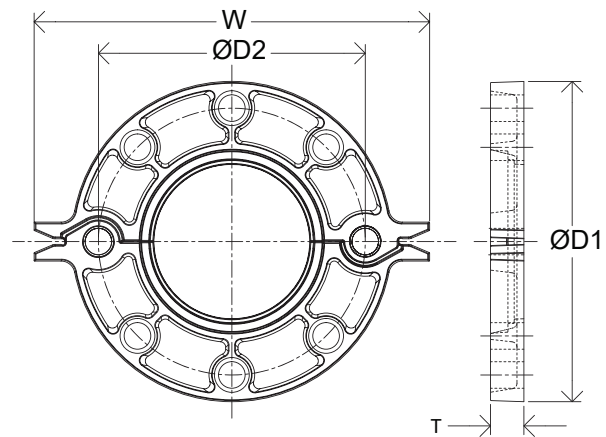

Specification

Nominal Size mm / in	Pipe O.D. mm / in	Maximum Working Pressure bar / psi	Dimensions				Weight kg / Lbs	Approval
			D1 mm / in	D2 mm / in	W mm / in	T mm / in		
50	60.3	35	155.4	120.6	215.2	23	1.84	UL
2	2.4	500	6.12	4.75	8.47	0.9	4.05	UL
65	73	35	183.1	139.7	236.6	23	2.35	UL
2½	2.87	500	7.21	5.5	9.31	0.9	5.18	UL
80	88.9	35	193.1	152.4	253.2	23	2.50	UL
3	3.5	500	7.6	6.0	9.97	0.9	5.51	UL
100	114.3	35	231.7	190.5	285.6	24	3.55	UL
4	4.5	500	9.12	7.5	11.24	0.94	7.82	UL
150	168.3	20	283.7	241.3	346.6	24	4.62	UL
6	6.6	300	11.17	9.5	13.64	0.94	10.18	UL
200	219.1	20	338.0	298.4	412.0	28	7.07	UL
8	8.6	300	13.3	11.75	16.2	1.1	15.58	UL

Housing

FLUID[®] Split Flange Housings are made of Ductile Iron conforming to ASTM A536 Gr. 65-45-12
Ductile iron is an ideal material for grooved mechanical components, as it provides similar or greater strength to that of wrought or cast steel materials

Chemical Properties

Percent (%)	Carbon C	Silicon Si	Manganese Mn	Phosphorous P	Sulphur S	Magnesium Mg	Chromium Cr
Min - Max	3% - 3.9%	2.5% - 3.2%	0.1% - 0.4%	0% - 0.07%	0% - 0.03%	0.03% - 0.06%	0% - 0.1%

Physical Properties

Minimum Tensile Strength	Minimum Yield Strength
448 MPa	310 MPa
65,000 psi	45,000 psi

Gaskets

FLUID[®] Gaskets are made with EPDM rubber compound conforming to ASTM D2000 with properties equal or greater to required as per AWWA C606.

EPDM gaskets are suitable for water, waste water, sea water and deionized water.

EPDM gaskets are not suitable for petroleum based oils, fuels and hydrocarbon solvents.



Physical Properties

Material	Colour Code	Shore Hardness	Maximum Specific Gravity	Maximum Ash Content	Minimum Tensile Strength	Minimum Elongation %
EPDM	Green Mark	65 ± 5	1.1%	5%	10.34 MPa 1500 psi	300%

Bolts and Nuts

FLUID[®] Bolts are hex bolts made of carbon steel conforming to ISO 8.8 and Nuts are heavy duty manufactured. The bolts and Nuts are galvanised.



Chemical & Physical Properties of Bolts

Carbon C	Phosphorous P	Sulphur S	Chromium Cr	Tensile Strength	Yield Strength
0.3% Min.	0.05% Max	0.06% Max	0% - 0.1%	760 MPa 110,000 psi	550 MPa 80,000 psi

Note:

The information contained in this document is subject to change without notice due to continuous improvement process. FLUID shall not be liable for any errors contained herein.

Style 378

Straight Connector - Grooved/Threaded

- FLUID Grooved/Threaded Straight Connector style 378 designed for short center to end dimensions it helps in easier installation in less space.
- FLUID Grooved/Threaded Straight Connector are primarily designed for fire protection applications, can also be used for general services.
- Maximum working pressure 300 psi.
- FLUID Grooved/Threaded Straight Connector housings are made of Ductile Iron conforming to ASTM A536.
- Standard Finish: Red painted RAL 3000.
Optional Finish: Galvanised or any other RAL color available on request.

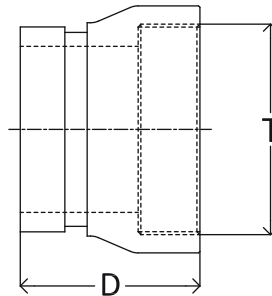

Specification

Nominal Size mm / in	Pipe O.D. mm / in	Thread Size T	Dimensions D mm / in	Weight kg / Lbs	Approval
65	73	2½" NPT/BSPT	64	0.751	-
2½	2.875	2½" NPT/BSPT	2.52	1.66	-

Housing

FLUID Straight Connector are made of Ductile Iron conforming to ASTM A536 Gr. 65-45-12. Ductile iron is an ideal material for grooved mechanical components, as it provides similar or greater strength to that of wrought or cast steel materials

Chemical Properties

Percent (%)	Carbon C	Manganese Mn	Phosphorous P	Sulphur S	Magnesium Mg	Chromium Cr
Min - Max	3% - 3.9%	0.1% - 0.4%	0% - 0.07%	0% - 0.02%	0.03% - 0.05%	0% - 0.1%

Physical Properties

Minimum Tensile Strength	Minimum Yield Strength
448 MPa	310 MPa
65,000 psi	45,000 psi

Note:

The information contained in this document is subject to change without notice due to continuous improvement process. FLUID shall not be liable for any errors contained herein.

Model 390

Lubricant

- FLUID® lubricant Model 390 is water dispersible.
- Suitable for all type of pipe lines.
- Will not deteriorate natural or synthetic gaskets or duct iron fittings.
- Excellent working temperature range form 12°C to 65°C.
- Contains no petroleum.
- Non toxic and biodegradable.
- Will not support bacteria.
- Meet NSF Standard #61, drinking water system components.



The FLUID® lubricant model 390 must always be used for proper coupling / fitting installation. The lubricant prevents the gasket from being pinched during coupling / fitting assembly, which will result in leakages.

Application

FLUID® Model 390 should be applied in an even and thin amount over the parts to be lubricated. Avoid applying excessive amounts. The best application is achieved when applying by hand. Clean all dirt, burrs and foreign matter from the joint surfaces. Make certain the gasket is properly located. Apply an even coating of lubricant to all fitting surfaces and gasket exterior and for interior. Assemble the joint according to the FLUID® assembly instructions.

FLUID® model 390 utilises environmentally friendly raw materials common in the soap and lubricant industries. It will not irritate the hands and is not toxic. It can be cleaned using warm water and soap. Does not contain petroleum oils or phosphates.

Technical Data

Form: Soft Past

Colour: Amber/Tan

Odour: Bland

pH: Approximately 9.5

Free Fatty Acid: 1-3%

Total Alkalinity: Approximately 100 mg KOH equivalent per gram

The below table will give an indication on the number of gaskets which can be lubricated with 1 kg lubricant.

Size	No. of Gaskets
50mm / 2"	440
65mm / 2½"	360
80mm / 3"	300
100mm / 4"	220
150mm / 6"	135
200 mm / 8"	110
250 mm / 10"	85
300 mm / 12"	65
350 mm / 14"	55
400 mm / 16"	50
450 mm / 18"	38
500 mm / 20"	33
600 mm / 24"	20

Disclaimer

DO NOT ALTER THE CONSISTENCY OF THIS PRODUCT. Use as is directly from the container. Keep away from your mouth and eyes. If eye contact occurs, flush with water for 5 minutes. If discomfort persists get medical attention. Will stain untreated porous surfaces such as concrete if not cleaned from the surface immediately.

Caution!!

Avoid contact with eyes, wash thoroughly after use. See material data sheet for additional safety and disposal information.

Note:

The information contained in this document is subject to change without notice due to continues improvement process. FLUID shall not be liable for any errors contained herein.



FACTORY (IND)
7/222, Nagamanaickenpalayam
Pattanam, Coimbatore - 641016
Tamil Nadu, India

FOUNDRY (IND)
Gas Company Road
Idikarai, Coimbatore - 641022
Tamil Nadu, India

WAREHOUSE (UAE)
Plot: 599-2285
Jebel Ali Industrial Area-1
Dubai, UAE



Certificate of Compliance

This certificate is issued for the following:

Non-Gasketed Pipe Fittings for Aboveground Fire Protection Systems

Model 371 Grooved End Cap	Model 350 90 Degree Grooved Elbow	Model 358 Equal Tee	Model 359 Grooved Reducing Tee
Model 361 Grooved Concentric Reducer	Model 351 45 Degree Grooved Elbow	Model 373 Grooved Outlet Flange Adapter	

Prepared for:

Fluid Pumps & Equipment India Pvt. Ltd
7/222 Nagamanaickenpalayan
Pattanam, Coimbatore
Tanil Nadu, 641016
India

Manufactured at:

Fluid Pumps & Equipment India Pvt. Ltd
7/222 Nagamanaickenpalayan
Pattanam, Coimbatore
Tanil Nadu, 641016
India

FM Approvals Class: 1920 - "Pipe Couplings and Fittings for Aboveground Fire Protection Systems"

Approval Identification: 3057770

Approval Granted: March 3, 2017

To verify the availability of the Approved product, please refer to www.approvalguide.com

Said Approval is subject to satisfactory field performance, continuing Surveillance Audits, and strict conformity to the constructions as shown in the Approval Guide, an online resource of FM Approvals.

A handwritten signature in black ink, appearing to read 'D.B. Fuller'.

David B. Fuller
AVP, Manager of Fire Protection
FM Approvals
1151 Boston-Providence Turnpike
Norwood, MA 02062 USA



Member of the FM Global Group

Confirmation Letter



UL CUSTOMER FLUID PUMPS & EQUIPMENT INDIA PVT LTD
7/222 Nagamanaickenpalayam Pattanam
Coimbatore, Tamil Nadu 641016 India

UL CUSTOMER FILE # EX16197
CATEGORY Fittings, Rubber Gasketed | VIZM

May 17, 2022

As of the above date, UL LLC confirms that FLUID PUMPS & EQUIPMENT INDIA PVT LTD is the party associated with UL File # EX16197 that appears in the UL Product iQ platform. Public information contained in UL File # EX16197 can be viewed using the following link:

<https://iq.ulprospector.com/en/profile?e=159849>

The appearance of a company's name or a specific product/component designation in the UL Product iQ platform does not in itself mean that product or component so specified or identified is subject to UL's Surveillance Program.

The manufacturer's products are not covered under UL's Surveillance Program unless they bear the authorized UL Mark. Therefore, only those products bearing the appropriate authorized UL Mark or UL Recognized Component Mark, the authorized company name, tradename, trademark and product designation shall be considered as being covered by UL's Listing, Classification, or Recognition Service.

If you have questions regarding this letter, please contact the UL Customer Experience Center at cec@ul.com.

Sincerely,

Leadership & Governance Team
UL Product iQ

VIZM.EX16197 - Fittings, Rubber Gasketed

Fittings, Rubber Gasketed

[See General Information for Fittings, Rubber Gasketed](#)

FLUID PUMPS & EQUIPMENT INDIA PVT LTD

7/222 Nagamanaickenpalayam Pattanam
Coimbatore, Tamil Nadu 641016 INDIA

Flexible coupling

EX16197

Model	Groove Type	Pipe	Size (in.)	Rated Pressure (psig)
Style 313	Rolled	10	2, 2-1/2, 3, 4	300
Style 313A	Rolled	10	2, 2-1/2, 3	300
Style 313	Rolled, Cut	40	1-1/2, 2, 2-1/2, 3, 4	500
Style 313A	Rolled, Cut	40	2, 2-1/2, 3	500
Style 313	Rolled, Cut	40	6, 8, 10, 12	300
Style 313	Rolled	EN	2, 3 OD, 3, 4	300

Rigid coupling

Model	Groove Type	Pipe	Size (in.)	Rated Pressure (psig)
Style 311	Rolled, Cut	40	1, 1-1/4, 1-1/2, 2, 2-1/2, 3	750
Style 311	Rolled, Cut	40	4	500
Style 311	Rolled, Cut	40	6	400
Style 311	Rolled, Cut	40	8, 10, 12, 14, 16, 24	300
Style 311	Rolled, Cut	EN	3OD	750
Style 311	Rolled, Cut	EN	6-1/2OD	400

Flexible Reducing Coupling (for use with grooved end pipe)

Model	Groove Type	Pipe	Size (in.)	Rated Pressure (psig)
Style 316	Rolled, Cut	40	2 x 1-1/2, 2-1/2 x 2, 3 x 2, 3 x 2-1/2, 4 x 3	500
Style 316	Rolled, Cut	40	6 x 4	400

Grooved Split Flange (for use with grooved end pipe)

Model	Groove Type	Pipe	Size (in.)	Rated Pressure (psig)
Style 375	Rolled, Cut	40	2, 2-1/2, 3, 4	500
Style 375	Rolled	40	6, 8	300

Side outlet

Model	Outlet Type	Pipe	Size (in.)	Rated Pressure (psig)
Style 309	Threaded	10	2 x 1/2, 2 x 3/4, 2 x 1, 2-1/2 x 1/2, 2-1/2 x 3/4, 2-1/2 x 1	300
Style 309	Threaded	40	1-1/2 x 1/2, 1-1/2 x 1, 2 x 1/2, 2 x 3/4, 2 x 1, 2-1/2 x 1/2, 2-1/2 x 3/4, 2-1/2 x 1, 3 x 1/2, 3 x 1, 4 x 1/2, 4 x 1, 6 x 1/2, 6 x 1	500
Style 309	Threaded	EN	2 x 1/2, 2 x 3/4, 2 x 1, 3 OD x 1/2, 3 OD x 3/4, 3 OD x 1	300
Style 300	Grooved	10	4 x 2, 4 x 2-1/2	300
Style 300	Grooved	40	3 x 2, 4 x 3	500
Style 300	Grooved	40	4 x 2, 4 x 2-1/2, 6 x 2, 6 x 2-1/2	400
Style 300	Grooved	40	6 x 4, 8 x 2, 8 x 2-1/2	300
Style 300	Grooved	EN	4 x 2, 4 x 3 OD	300
Style 305	Threaded	40	1-1/2 x 1, 2 x 1, 2 x 1-1/4, 2 x 1-1/2, 2-1/2 x 1, 2-1/2 x 1-1/4, 2-1/2 x 1-1/2, 3 x 1, 3 x 1-1/4, 3 x 1-1/2, 3 x 2, 4 x 1, 4 x 1-1/4, 4 x 1-1/2, 4 x 2, 6 x 1, 6 x 1-1/4, 6 x 1-1/2, 6 x 2	500
Style 305	Threaded	40	8 x 1, 8 x 1-1/4, 8 x 1-1/2, 8 x 2	300

10 refers to Schedule 10 steel pipe in accordance with NFPA 13.

40 refers to Schedule 40 steel pipe in accordance with NFPA 13.

Model 313 is suitable for use in dry pipe system for temperatures to -40°F.

EN refers to BS EN 10255:2004 steel tubes Type M and Type H.

1 in. fittings in model Style 309 and 305 are for direct connection to system piping only.

Model 309 in the 1/2 and 3/4 in. nominal outlet sizes are intended for direct connection to sprinklers.

Trademark and/or Tradename:

FLUID

Last Updated on 2019-09-23

The appearance of a company's name or product in this database does not in itself assure that products so identified have been manufactured under UL's Follow-Up Service. Only those products bearing the UL Mark should be considered to be Certified and covered under UL's Follow-Up Service. Always look for the Mark on the product.

UL permits the reproduction of the material contained in the Online Certification Directory subject to the following conditions: 1. The Guide Information, Assemblies, Constructions, Designs, Systems, and/or Certifications (files) must be presented in their entirety and in a non-misleading manner, without any manipulation of the data (or drawings). 2. The statement "Reprinted from the Online Certifications Directory with permission from UL" must appear adjacent to the extracted material. In addition, the reprinted material must include a copyright notice in the following format: "© 2022 UL LLC"

Confirmation Letter



UL CUSTOMER FLUID PUMPS & EQUIPMENT INDIA PVT LTD
7/222 Nagamanaickenpalayam Pattanam
Coimbatore, Tamil Nadu 641016 India

UL CUSTOMER FILE # EX16287
CATEGORY Fittings, Grooved and Plain End | VIZA

May 17, 2022

As of the above date, UL LLC confirms that FLUID PUMPS & EQUIPMENT INDIA PVT LTD is the party associated with UL File # EX16287 that appears in the UL Product iQ platform. Public information contained in UL File # EX16287 can be viewed using the following link:

<https://iq.ulprospector.com/en/profile?e=159723>

The appearance of a company's name or a specific product/component designation in the UL Product iQ platform does not in itself mean that product or component so specified or identified is subject to UL's Surveillance Program.

The manufacturer's products are not covered under UL's Surveillance Program unless they bear the authorized UL Mark. Therefore, only those products bearing the appropriate authorized UL Mark or UL Recognized Component Mark, the authorized company name, tradename, trademark and product designation shall be considered as being covered by UL's Listing, Classification, or Recognition Service.

If you have questions regarding this letter, please contact the UL Customer Experience Center at cec@ul.com.

Sincerely,

Leadership & Governance Team
UL Product iQ

VIZA.EX16287 - Fittings, Grooved and Plain End

Fittings, Grooved and Plain End

[See General Information for Fittings, Grooved and Plain End](#)**FLUID PUMPS & EQUIPMENT INDIA PVT LTD**

EX16287

7/222 Nagamanaickenpalayam Pattanam

Coimbatore, Tamil Nadu 641016 INDIA

The following fittings are intended for use with Listed Rubber Gasketed fittings under UL file EX16197.

Grooved

Model	Type	Size In.	Rated Pressure (psig)
Style 350	90 degree elbow	1-1/2, 2, 2-1/2, 3 OD, 3, 4	500
Style 350	90 degree elbow	6, 8, 10, 12	300
Style 350A	90 degree elbow	2, 2-1/2, 3	500
Style 351	45 degree elbow	2, 2-1/2, 3 OD, 3, 4	500
Style 351	45 degree elbow	6, 8, 10	300
Style 358	Equal tee	1-1/2, 2, 2-1/2, 3 OD, 3, 4	500
Style 358	Equal tee	6, 8, 10, 12	300
Style 358A	Equal tee	2, 2-1/2, 3	500
Style 359	Reducing tee	2-1/2 x 2, 3 x 2, 3 x 2-1/2, 3 x 3 OD, 4 x 2-1/2, 4 x 3	500
Style 359	Reducing tee	6 x 2-1/2, 6 x 3, 6 x 4, 8 x 3, 8 x 4, 8 x 6, 10 x 8	300
Style 361	Concentric reducer	2 x 1-1/2, 2-1/2 x 2, 3 OD x 2, 3x2, 3 x 2-1/2, 4 x 1-1/2, 4 x 2, 4 x 2-1/2, 4 x 3, 6 x 2, 6 x 2-1/2	500
Style 361	Concentric reducer	6 x 3, 6 x 4, 8 x 4, 8 x 6, 10 x 4, 10 x 8, 12 x 8	300
Style 361A	Concentric reducer	2-1/2 x 2, 3 x 2-1/2	500

Style 363	Concentric reducer	2-1/2 x 1, 2-1/2 x 1-1/4, 2-1/2 x 1-1/2, 2-1/2 x 2, 3 x 1, 3 x 1-1/4, 3 x 1-1/2, 3 x 2, 3 x 2-1/2	500
Style 364	Long radius elbow	2, 2-1/2, 3, 4	500
Style 364	Long radius elbow	6, 8	300
Style 369	Reducing tee	2-1/2 x 2	500
Style 371	End cap	1-1/2, 2, 2-1/2, 3 OD, 3, 4, 6	500
Style 371	End cap	8, 10, 12, 14, 16	300
Style 373	Grooved flange	2-1/2, 3	350
Style 373	Grooved flange	4	500
Style 373	Grooved flange	6	200
Style 373	Grooved flange	8, 10	250
Style 373	Grooved flange	12, 14, 16	300

Trademark and/or Tradename:

FLUIDLast Updated on 2016-11-23

The appearance of a company's name or product in this database does not in itself assure that products so identified have been manufactured under UL's Follow-Up Service. Only those products bearing the UL Mark should be considered to be Certified and covered under UL's Follow-Up Service. Always look for the Mark on the product.

UL permits the reproduction of the material contained in the Online Certification Directory subject to the following conditions: 1. The Guide Information, Assemblies, Constructions, Designs, Systems, and/or Certifications (files) must be presented in their entirety and in a non-misleading manner, without any manipulation of the data (or drawings). 2. The statement "Reprinted from the Online Certifications Directory with permission from UL" must appear adjacent to the extracted material. In addition, the reprinted material must include a copyright notice in the following format: "© 2022 UL LLC"