

FLUID PUMPS & EQUIPMENT INDIA PVT. LTD.

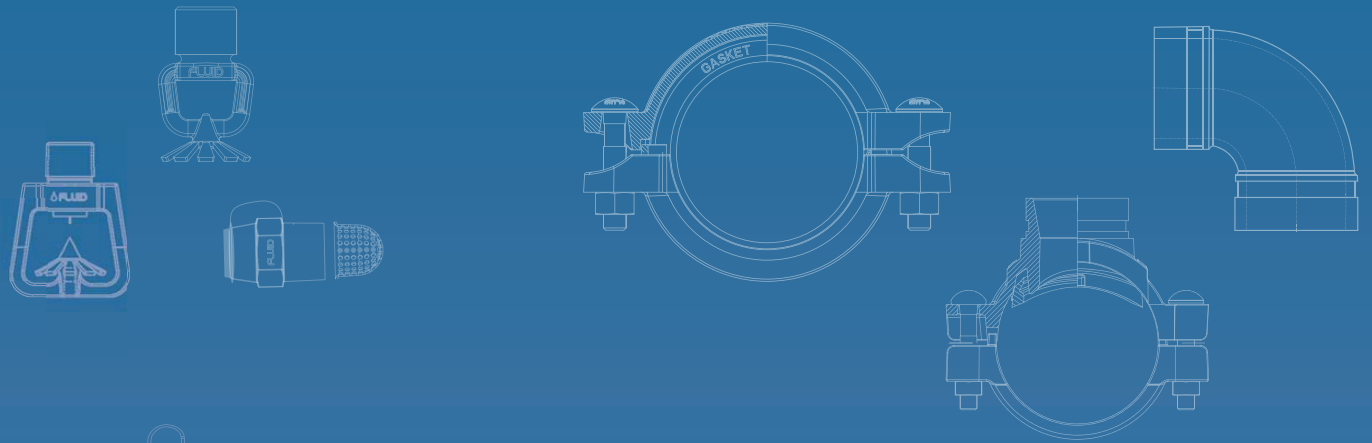

COMPANY PROFILE

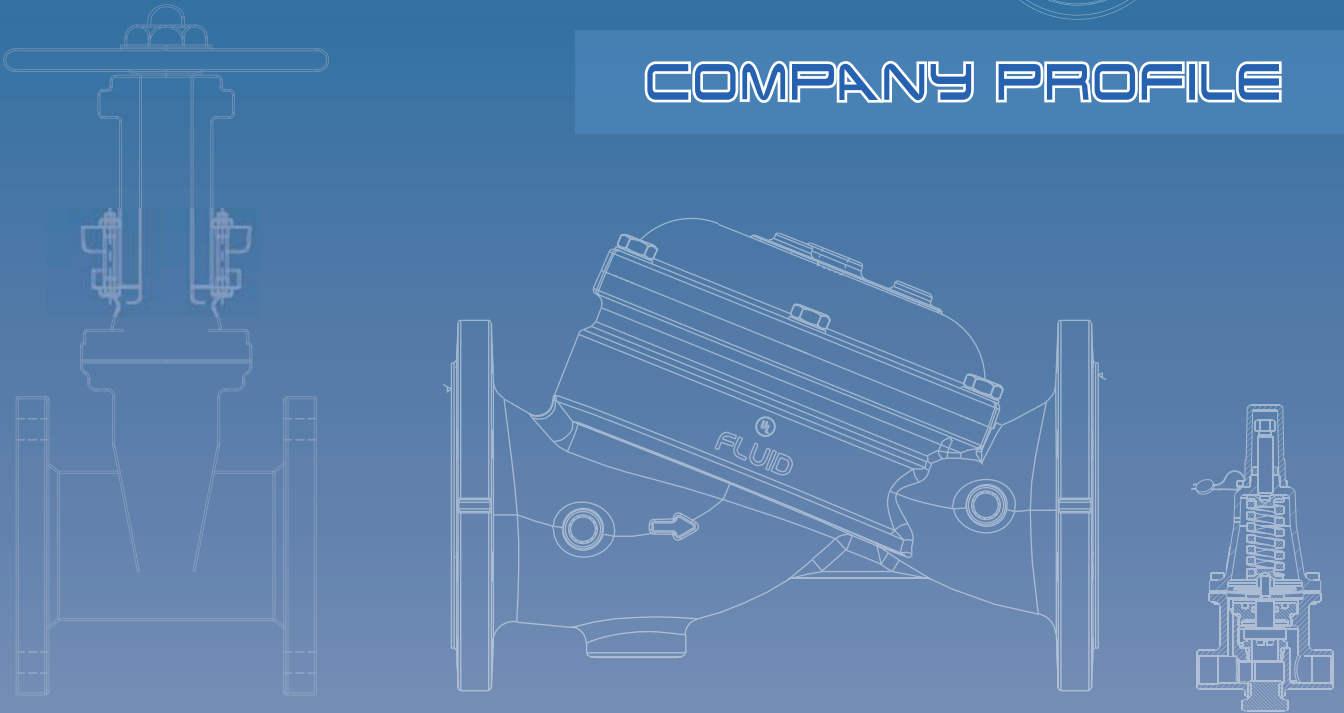

FLUID®

Global Presence



UAE
Plot No. 599-2285,
Jebel Ali Industrial Area-1,
Dubai, UAE.



INDIA
7/222, Nagamanaickenpalayam,
Pattanam Road, Coimbatore,
Tamil Nadu, India.



INDIA
791/1B1 & 1B2, Gas Company Road,
Idigarai, Coimbatore,
Tamilnadu, India.

Founded in 1978 in the United Kingdom, FLUID® has evolved from a modest engineering unit into a global leader in fire protection equipment. Our growth has established us as a prominent player in the Middle East and India, where we operate advanced manufacturing and distribution facilities.

In India, our state-of-the-art green foundry features cutting-edge technology such as Inductotherm™ Induction Furnaces and Disa® High-Pressure Automatic Moulding line. This enables us to produce premium ferrous and non-ferrous castings tailored to meet specific OEM requirements. Our Coimbatore facility is renowned for adhering to best manufacturing practices, employing automation and precision machinery to deliver superior quality.

We also operate a comprehensive in-house facility dedicated to rubber compounding, moulding, and testing. Here, we produce specialized seals, gaskets, and diaphragms that meet rigorous standards, including NSF61 and NSF372, ensuring suitability for applications such as drinking water systems.

FLUID's products undergo stringent testing to comply with international standards, and we hold certifications from UL and FM. Our offerings cater to a wide range of sectors, including oil & gas, petrochemical, utility, power, industrial, and commercial projects across Asia, the Middle East, Africa, Europe, North America, and the Far East.

Committed to innovation and quality, FLUID® delivers reliable solutions for industrial applications worldwide.

Infrastructure



Approvals

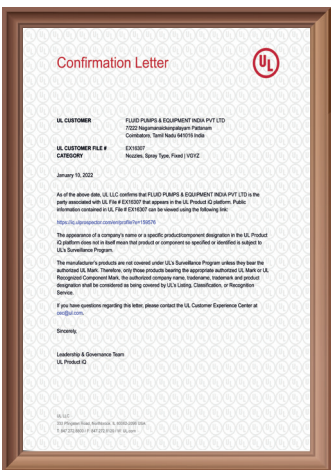



Deluge Valve

Water Motor Gong



Spray Nozzles

MVWS, HVWS
Foam Nozzles



FLUID® UL listed; model FX Deluge Valves are Diaphragm operated valves with no mechanical moving part & very low friction losses across the body. The valves are available from 1½" to 10" Size in ANSI Flange connections, other flanges or Grooved End are available on request. Valves are suitable for Vertical as well as Horizontal mounting.

FLUID® Deluge Valves are available in Ductile Iron, Cast Steel material of constructions. Stainless Steel & Ni-Al-Bronze body is also available for corrosive environments. FX Deluge Valves are supplied with Hydraulic, Electric or Pneumatic activation trims with Galvanized Steel piping & Brass valves as standard, Copper tubing or complete Stainless Steel valve trim is available for corrosive environment. The valves are rated for 250 psi (17.25 bar) working pressure.

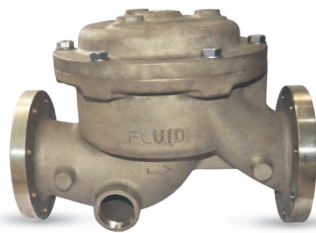

Ni-Al Bronze Body



Cast Steel Body

FLUID® UL listed; model 250 Water Motor Gong used with Deluge Valve or Sprinkler Alarm Check Valve mounted outside the building or near the valve station. Hydraulically driven, lightweight, compact and noncorrosive Aluminum body is designed to operate at the low pressure of 15 psi. Gong produces continuous piercing alarm at intensity of 90dB when the deluge spray or sprinkler system operates.

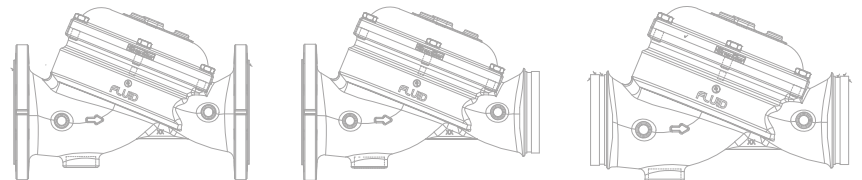

FLUID® UL listed model 212, 213 Medium Velocity & model 230 High Velocity Nozzles are used for Deluge spray system. MV Nozzles produces Cone shape spray pattern & HV Nozzles provides a full (Solid) cone pattern with uniform droplet distribution, HV Nozzles are ideal for exposure protection and to fight fuel fires.

FLUID® UL listed; model F226 Foam Nozzles produces & distribute foam when foam-water solution is discharged through them. Foam solution & nozzle combinations produces foam blankets providing burn back resistance & protection from reflash. Foam nozzles comes with Stainless Steel 316 screen as standard.

FLUID® Nozzles are suitable for installation in Pendent, Horizontal or Angle positions as per site requirement. Designed to produce extremely uniform coverage & having wide range of K Factors & Spray Angles. Nozzles are available with non-corrosive Brass body as standard & SS316 is also available as optional.

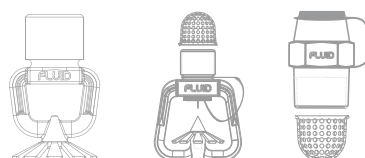



Grooved Fittings

Pipe Supports

FLUID® UL listed; Grooved pipe fitting systems are one of the most advance pipe connection systems of the day. Grooved Pipe fittings housings are made of Ductile Iron conforming to ASTM A536 with rated working pressure up to 750 psi (52 bar), supplied with Red Painted finish as standard, Galvanized Finish is available as optional.

Grooved End Fittings are UL Listed as well as FM Approved. Stainless Steel CF8M Fittings are available to use with corrosive medium.

FLUID® UL listed; Pipe supports are used in Fire Protection system as sprinkler pipe hanger & U Bolts. Swivel Ring Hanger complies to NFPA requirement. Fluid Pipe Hangers are available from ½" to 12" Sizes.

Gate Valves

Pressure Relief Valve

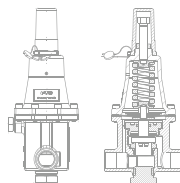

FLUID® Model F722 OS&Y Rising Stem Resilient seated Gate valves are designed & manufactured in accordance with BS 5163 Standard . Gate valves are intended to use in fire-protection systems, having rated working pressure of 250 psi (17.25 bar) & Ductile Iron material construction. The valves are available from 2" to 12" Size in ANSI Flange connections, other flanges or Grooved End are available on request. Tamper switch can be installed for supervisory purpose.

FLUID® Model 515, Air Release Valves are typically used in fire protection system as required by NFPA 13 for wet pipe sprinkler system & NFPA 20 for stationary fire pumps. Air Release Valve are mounted at highest points to Automatically release trapped air in wet systems.

FLUID® UL Listed Model 513 Pressure Relief Control Valve is a direct-acting, spring loaded, diaphragm type relief valve intended to prevent excess pressure built-up in systems where pressure level is critical for smooth operation. The valve can be installed in any position to open & shut within close pressure limits. Available in Globe & Angle type configuration it is field adjustable in pressure range from 20psi to 300psi. Model 513A is available in Stainless steel construction.

Deluge Skids/Cabinets

FLUID® Deluge skid / cabinets are pre-assembled packaged unit with Main control valve, Actuation trim set, system accessories etc. mounted in a single unit enabling quick installation of system at site. Our standard Deluge skid comes with advance Grooved pipe connections providing compact assembly, Fast dismantling & assembly of Skid components during maintenance. Quick replacement of components is possible without use of special tools/skilled manpower.

Skids are Designed, Engineered & Manufactured in accordance to the project requirements & with best engineering practices. Deluge skids can be provided with various customization in release trim such as On-Off/ Manual Reset Hydraulic, Electric, Pneumatic or Pre-action double interlock. Insulated skid cabinets can also be provided for operating in sub-zero temperature regions by maintaining preset temperature inside skid. Specialized in custom built skid complying to meet the stringent requirements of offshore, oil & gas industry. We design, manufacture, fabricate and assemble in house with stringent QA/QC & NFPA Standards



Skids For Offshore, Oil & Gas Industry

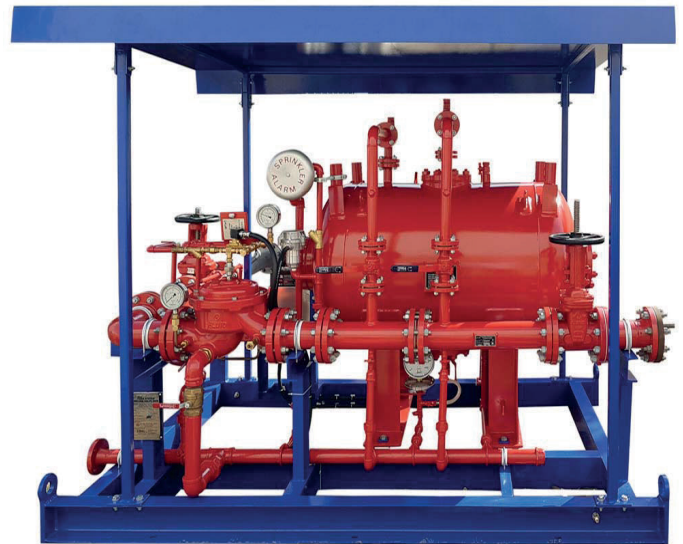
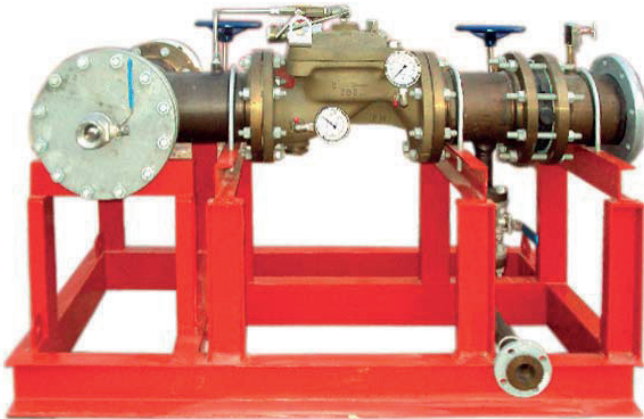

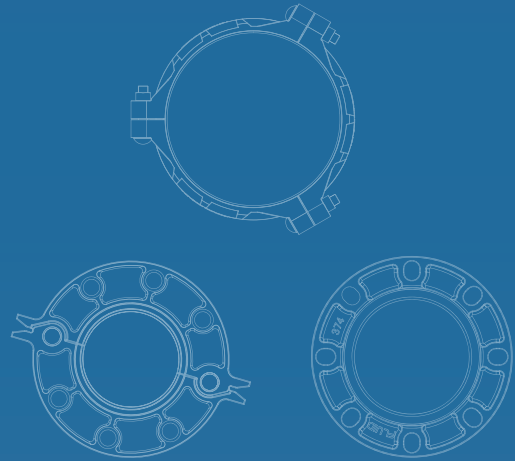
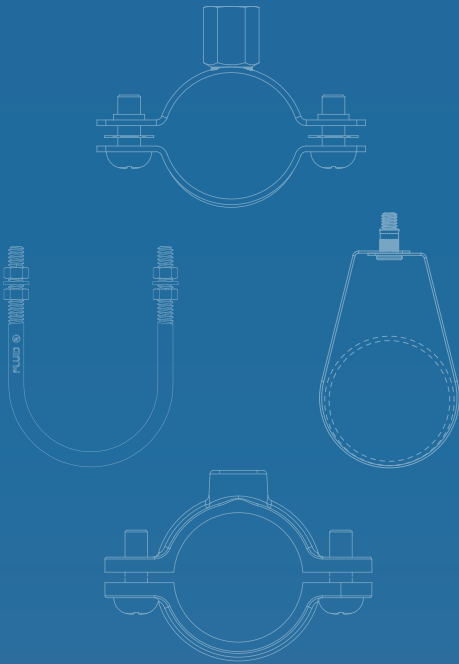

www.fluidequipment.in

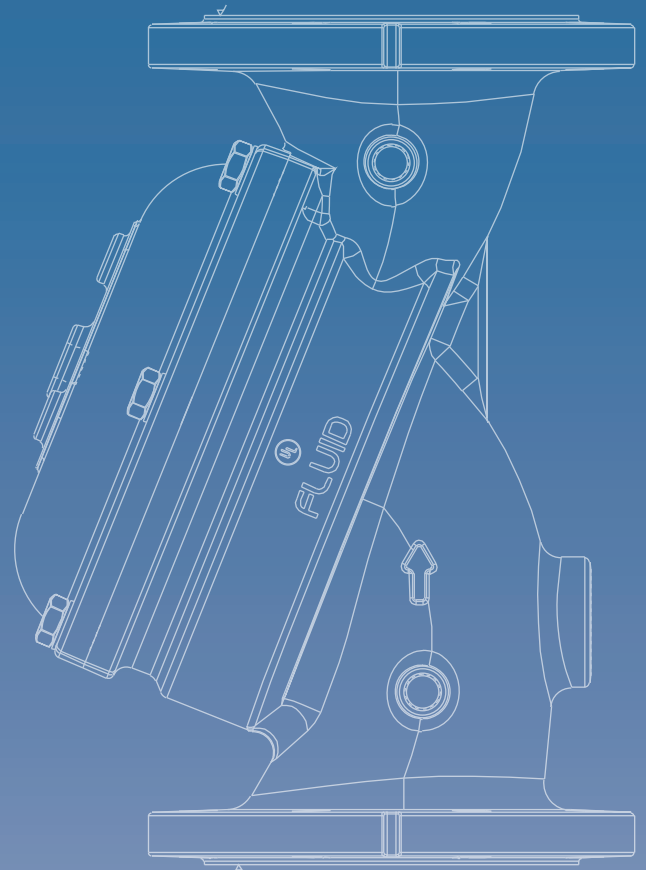
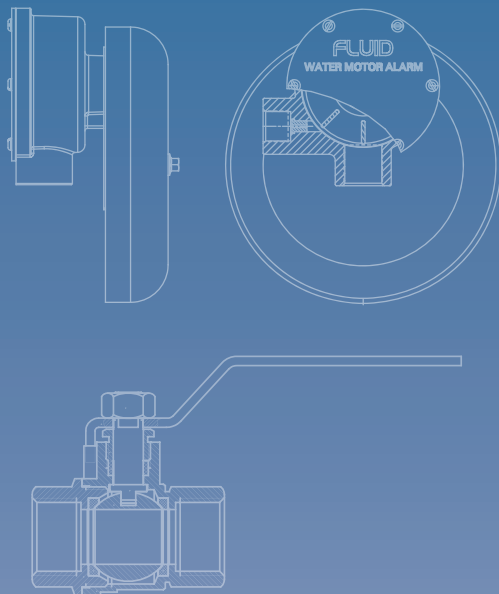

FACTORY (IND)
7/222, Nagamanaickenpalayam
Pattanam, Coimbatore - 641016
Tamil Nadu, India

FOUNDRY (IND)
Gas Company Road
Idikarai, Coimbatore - 641022
Tamil Nadu, India

WAREHOUSE (UAE)
Plot: 599-2285
Jebel Ali Industrial Area-1
Dubai, UAE